





City of Chino "The Preserve" - Street DIF Tract Map 18480 (Harvest)

Updated 3/12/2024

CFD Streets (Harvest)

	Description	Quantity	Unit
	Alpine Meadows Ave.	813	ft
	Bickmore Ave.	1,819	ft
	Hellman Ave.	2,140	ft
	Pine Ave	1,729	ft

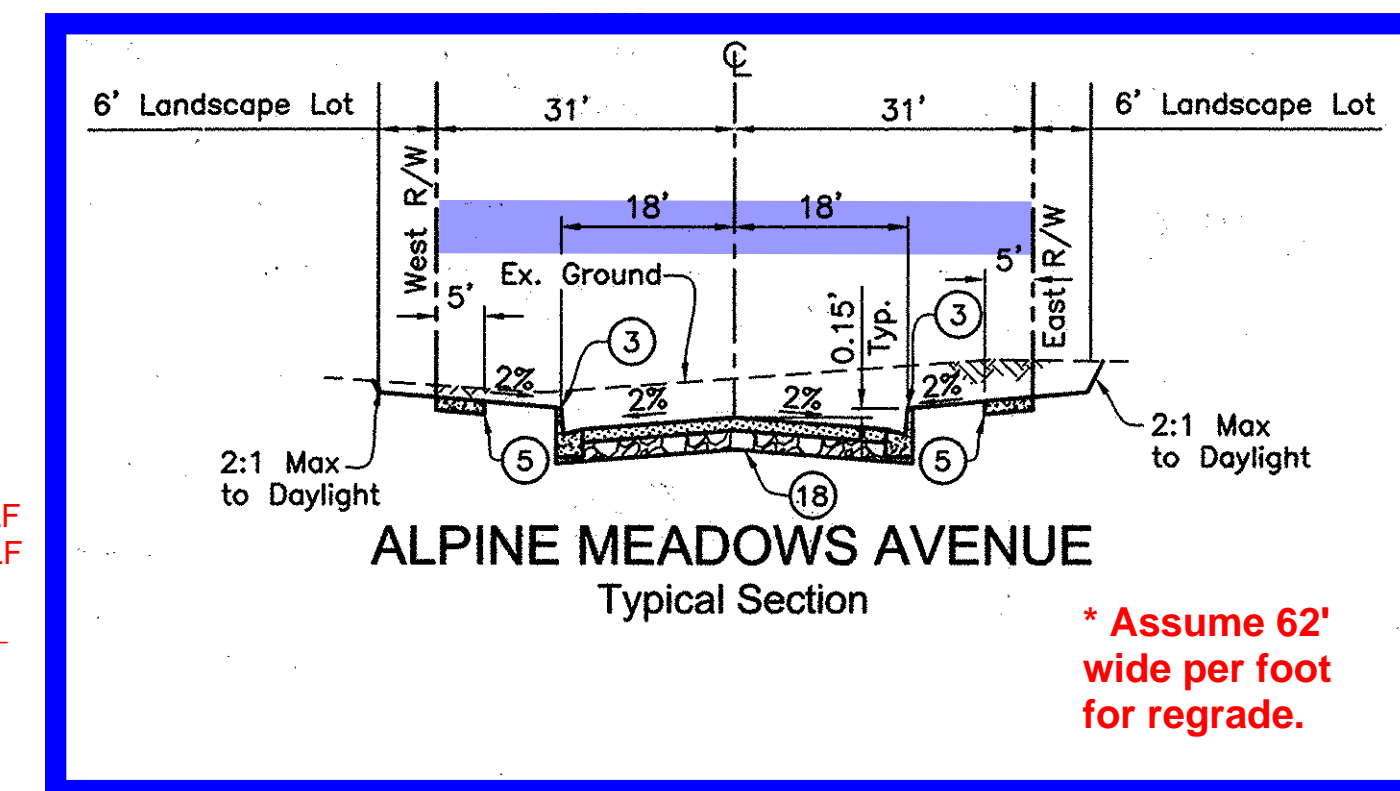

Alpine Meadows Ave

AC Pavement = \$2.75/SF x 32' = \$88.00/LF
 Sidewalk = \$3.30/SF x 10' = \$33.30/LF
 Landscape = \$8.00/SF x 16' = \$128/LF
 C&G = \$18/LF x 2 = \$36.00/LF
Total (per LF of Road) = 285.30/LF

* Note: Unit prices per CFD contract

Assume 62' wide improvements:
 \$285.30/LF x 813 LF = \$231,948.90

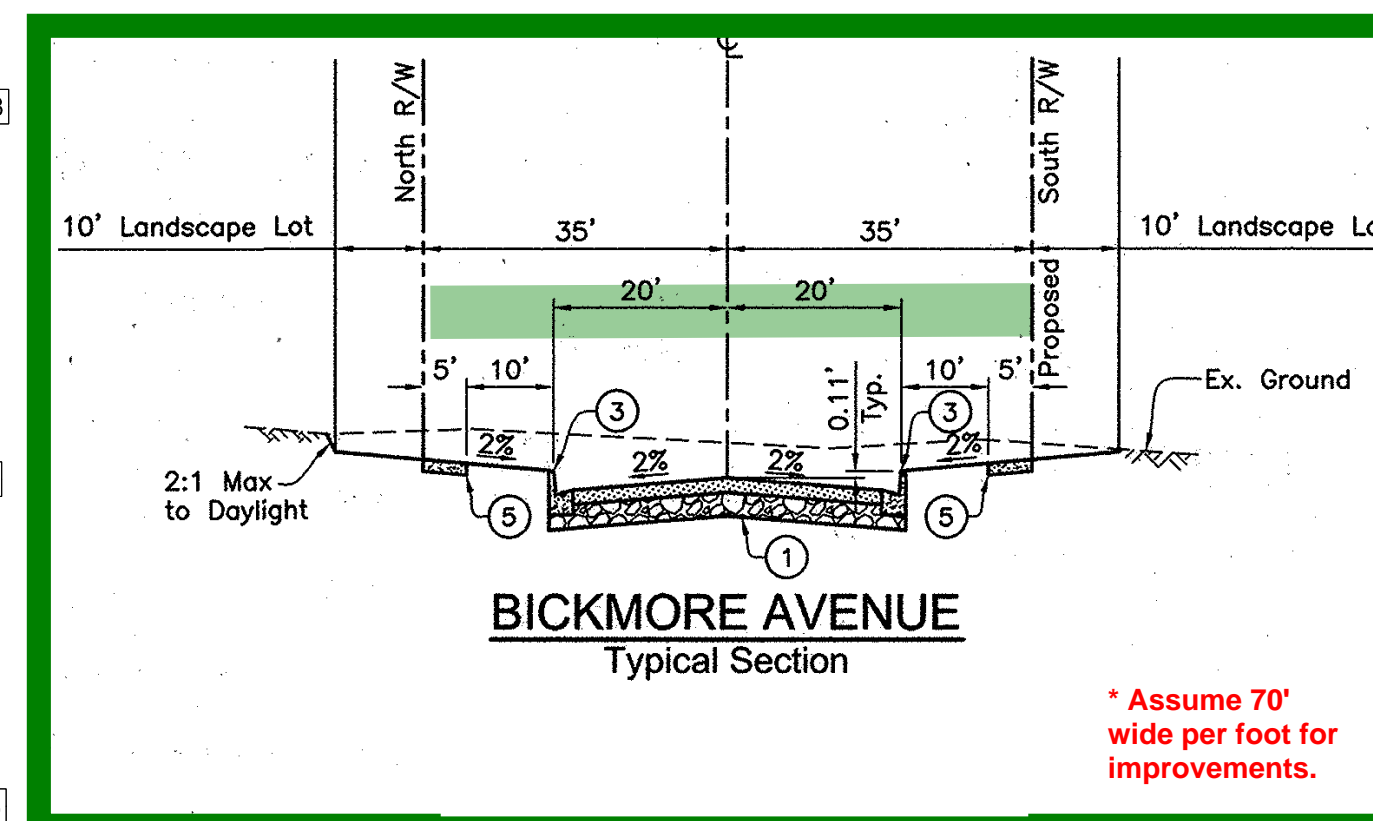

Assume 70' wide improvements:
 70' x 1,819 LF = 127,330 SF

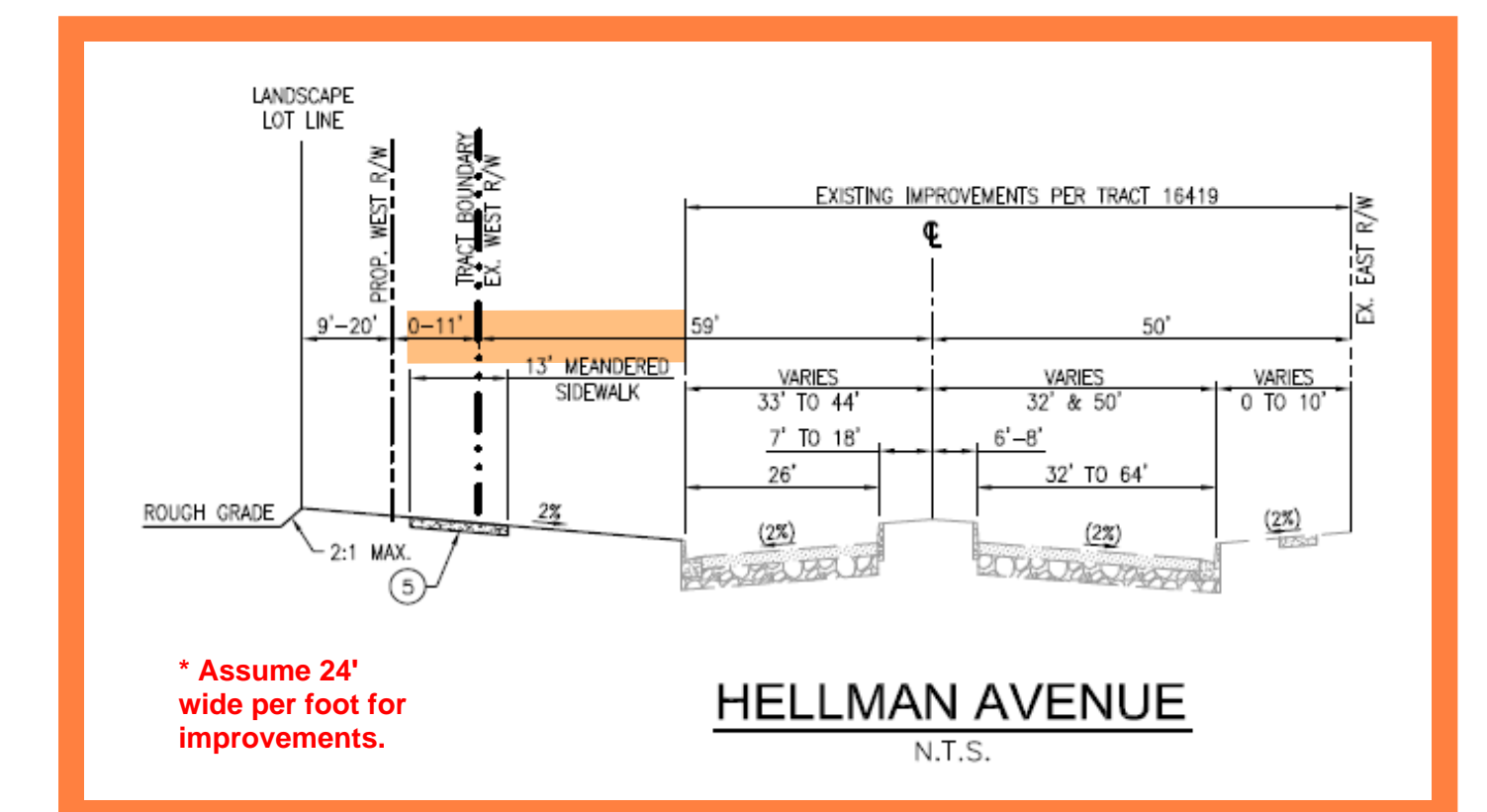

Assume 24' wide improvements:
 24' x 2,140 LF = 51,360 SF

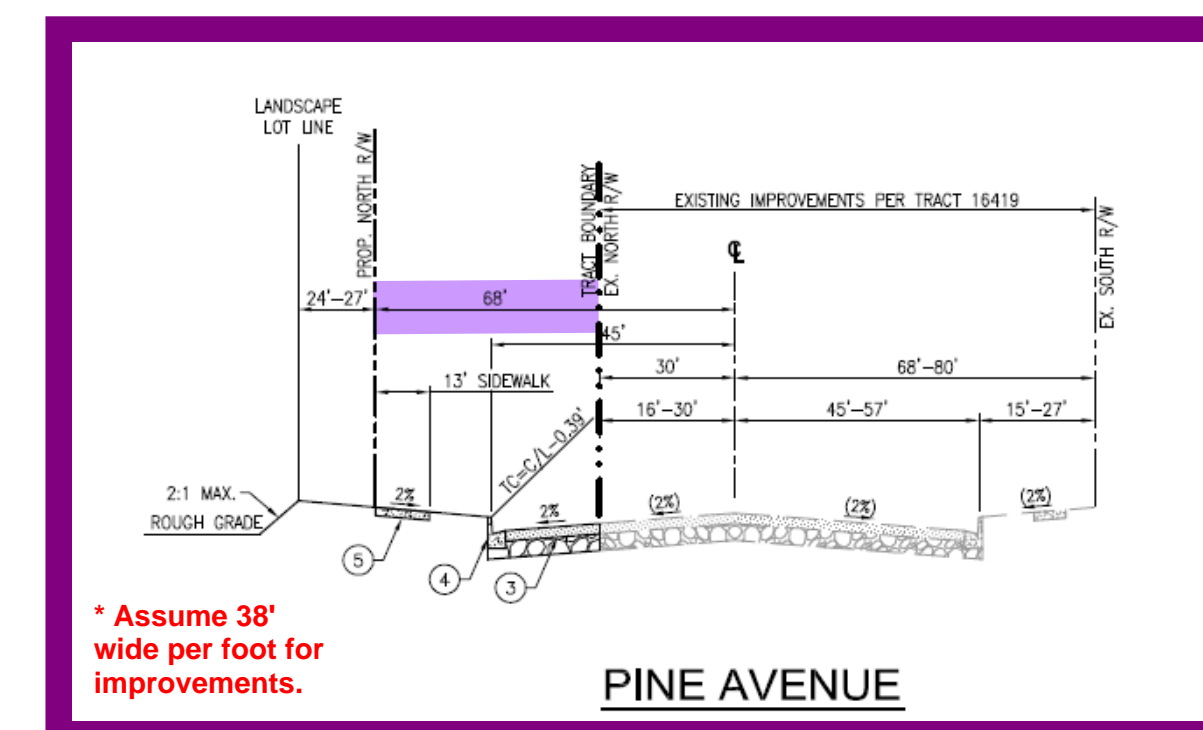

Assume 38' wide improvements:
 38' x 1,729 LF = 65,702 SF

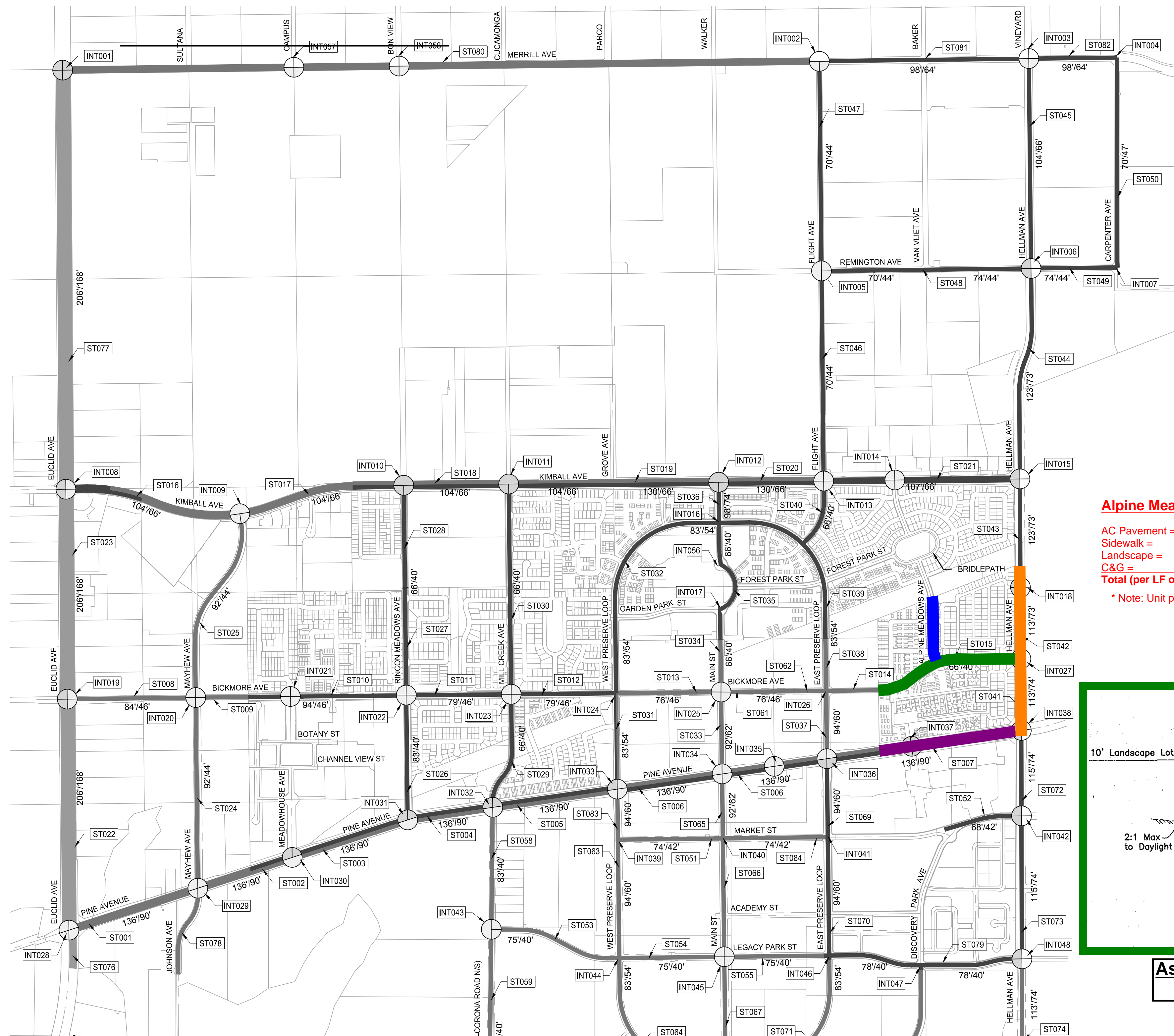

Street Name	Street SF	Total SF (All Streets)	% of Total	Total DIF Cost (All Streets)	Street Cost	Total DIF Street Cost
Street Cost					\$4,164,539.78	
Alpine Meadows					\$ (231,948.90)	
DIF Street Cost Total					\$3,932,590.88	
Bickmore Ave	127,330	244,392	52.10%	\$3,932,590.88		\$2,048,908.30
Hellman Ave	51,360	244,392	21.02%	\$3,932,590.88		\$826,450.41
Pine Ave	65,702	244,392	26.88%	\$3,932,590.88		\$1,057,232.18
	244,392		100.00%			\$3,932,590.88

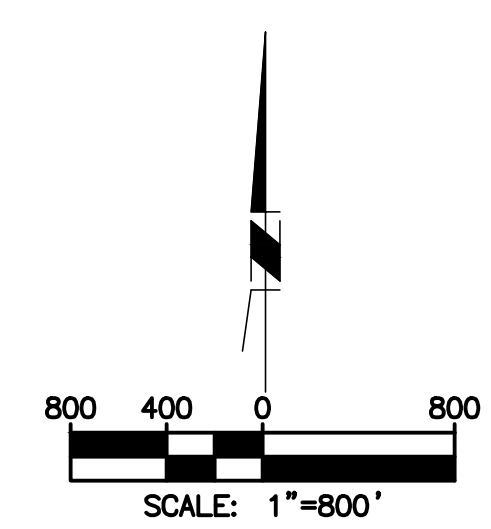

City of Chino "The Preserve" - Street DIF Tract Map Nos. 16420-1 & 16420-2

Updated 3/12/2024

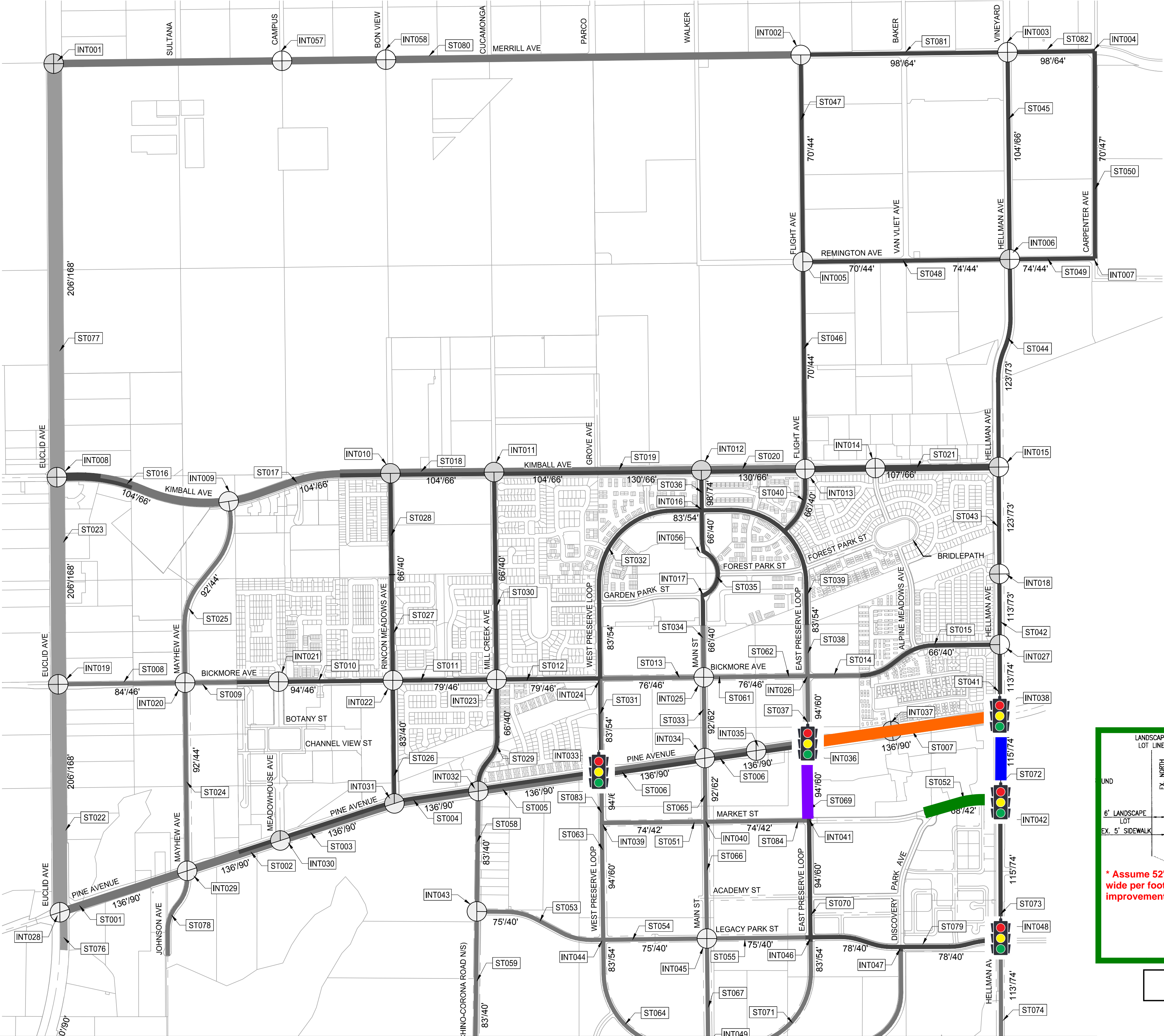

CFD Streets			
	Description	Quantity	Unit
/	East Preserve Loop	953	ft
/	Hellman Ave	1,094	ft
/	Market Street	987	ft
/	Pine Ave	2,453	ft

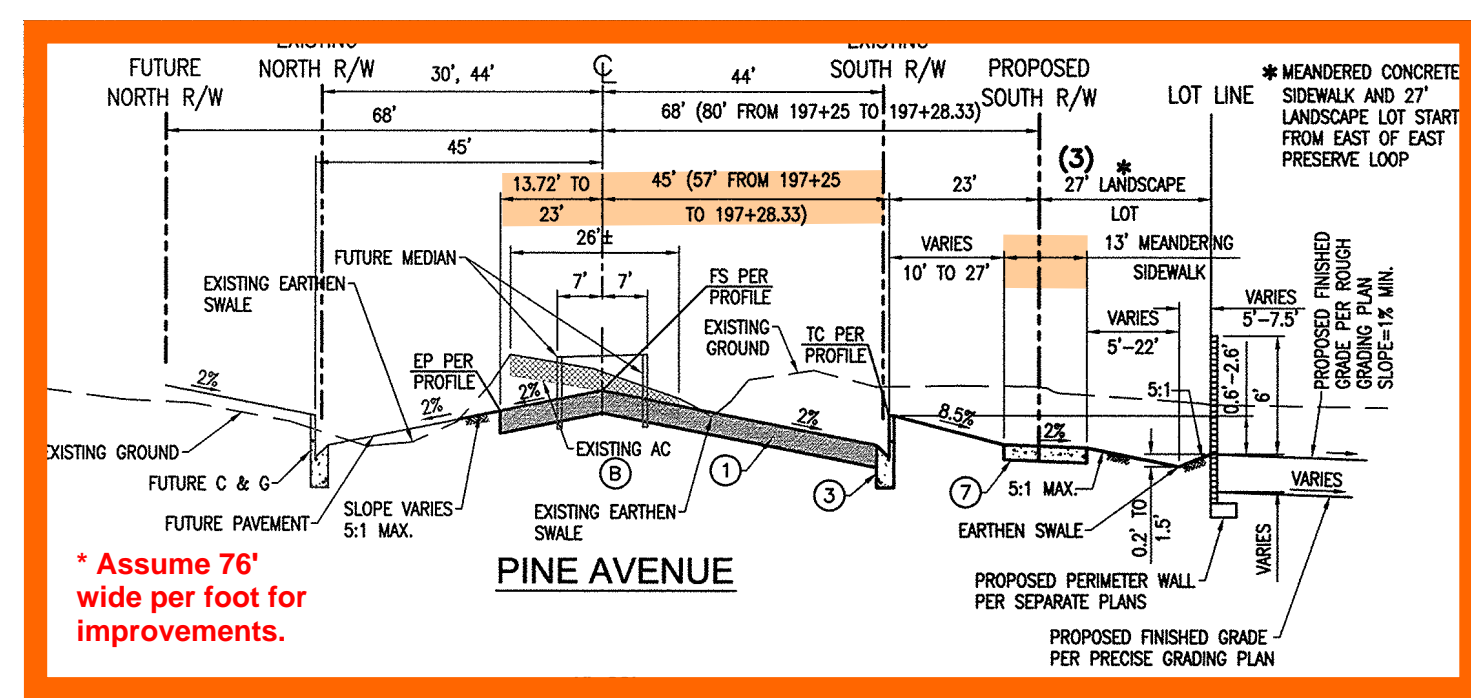

Assume 76' wide improvements:
76' x 2,453 LF = 186,428 SF

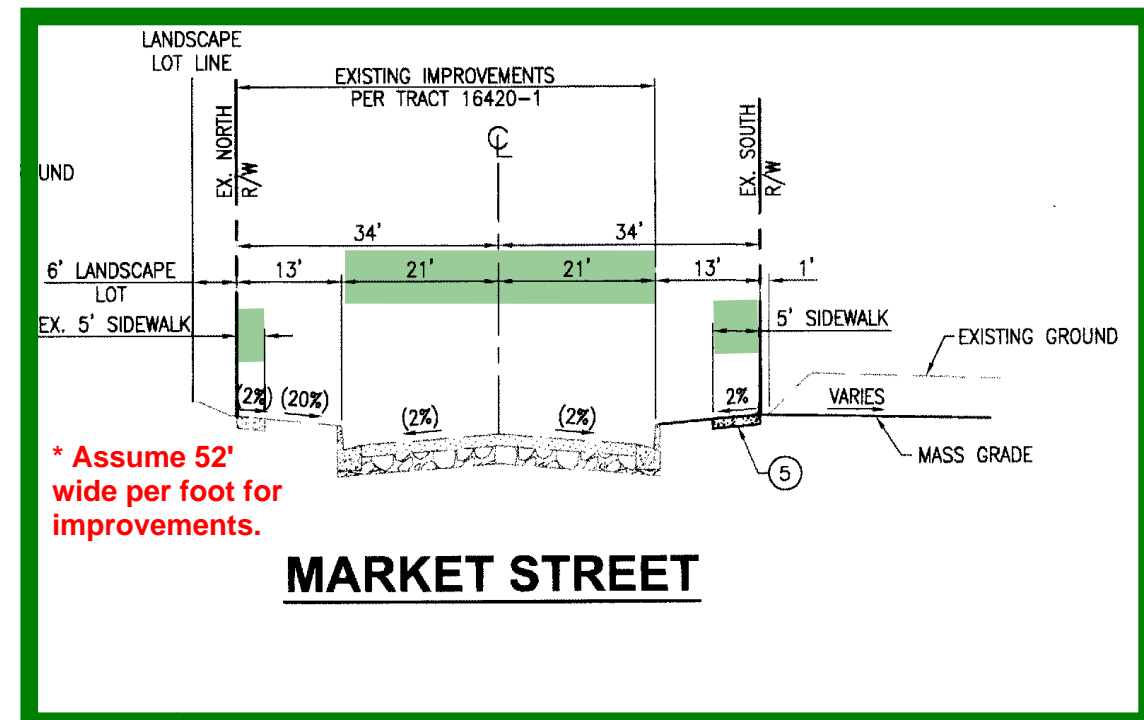

Assume 52' wide improvements:
52' x 987 LF = 51,324 SF

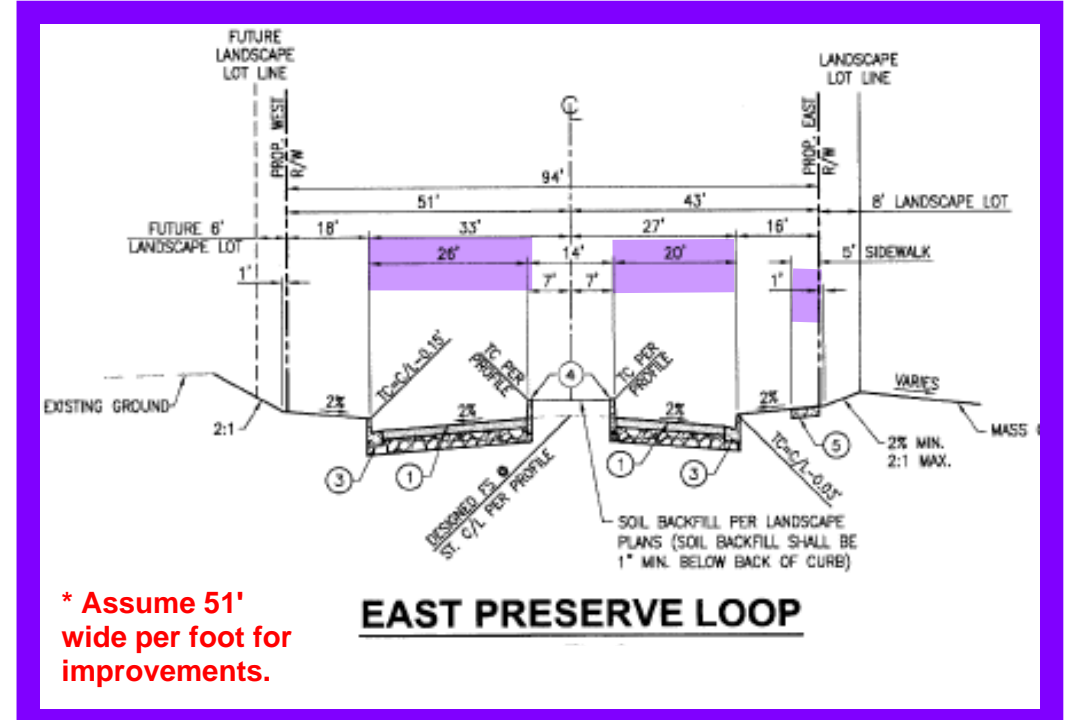

Assume 51' wide improvements:
51' x 953 LF = 48,603 SF

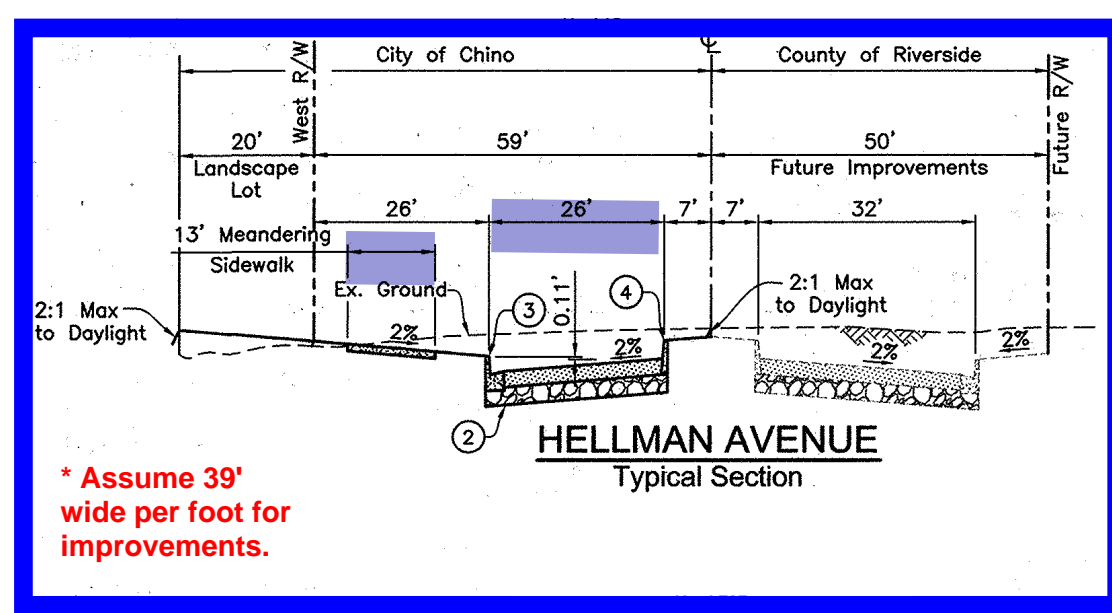

Assume 39' wide improvements:
39' x 1,094 LF = 42,666 SF

Street Name	Street SF	Total SF (All Streets)	% of Total	Total Cost (All Streets)	Total DIF Street Cost
East Preserve Loop	48,603	329,021	14.77%	\$4,477,940.54	\$661,481.62
Hellman Ave	42,666	329,021	12.97%	\$4,477,940.54	\$580,679.69
Market Street	51,324	329,021	15.60%	\$4,477,940.54	\$698,514.14
Pine Ave	186,428	329,021	56.66%	\$4,477,940.54	\$2,537,265.10
	329,021		100.00%		\$4,477,940.54

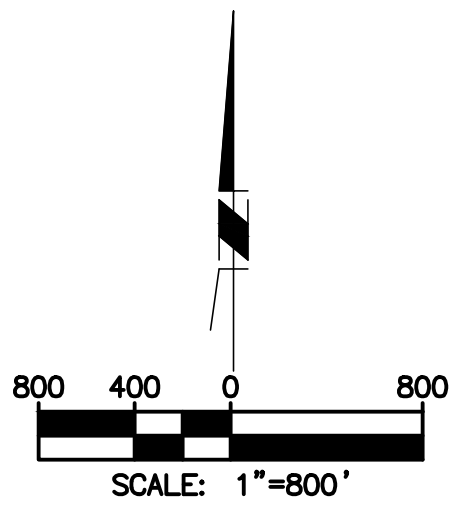

City of Chino "The Preserve" - Street DIF Tract Map No. 1994

Updated 3/12/2024

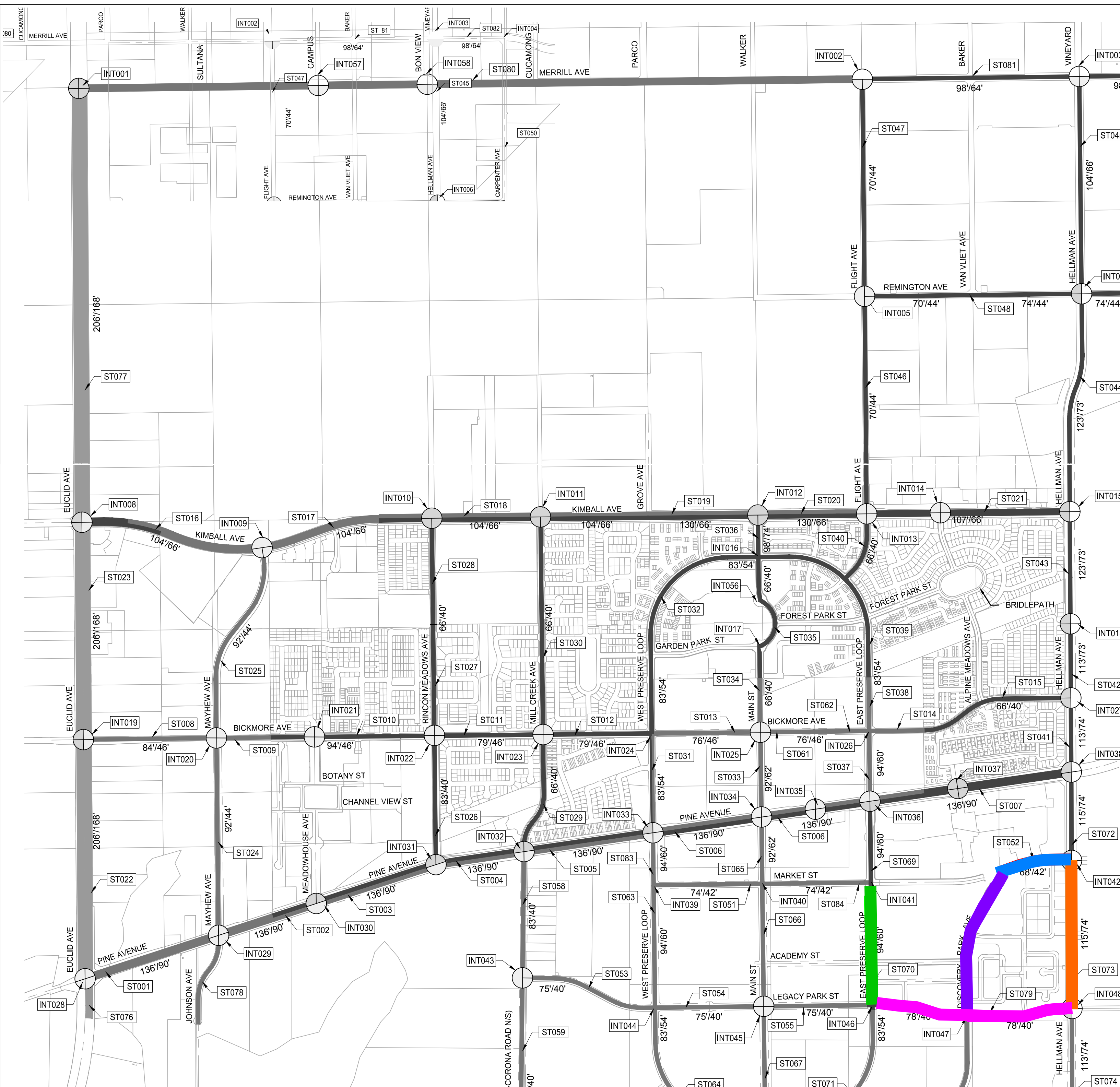

CFD Streets			
	Description	Quantity	Unit
	Discovery Park Ave.	1,823	ft
	East Preserve Loop	1,440	ft
	Hellman Ave	1,805	ft
	Legacy Park St.	2,402	ft
	Market St.	929	ft

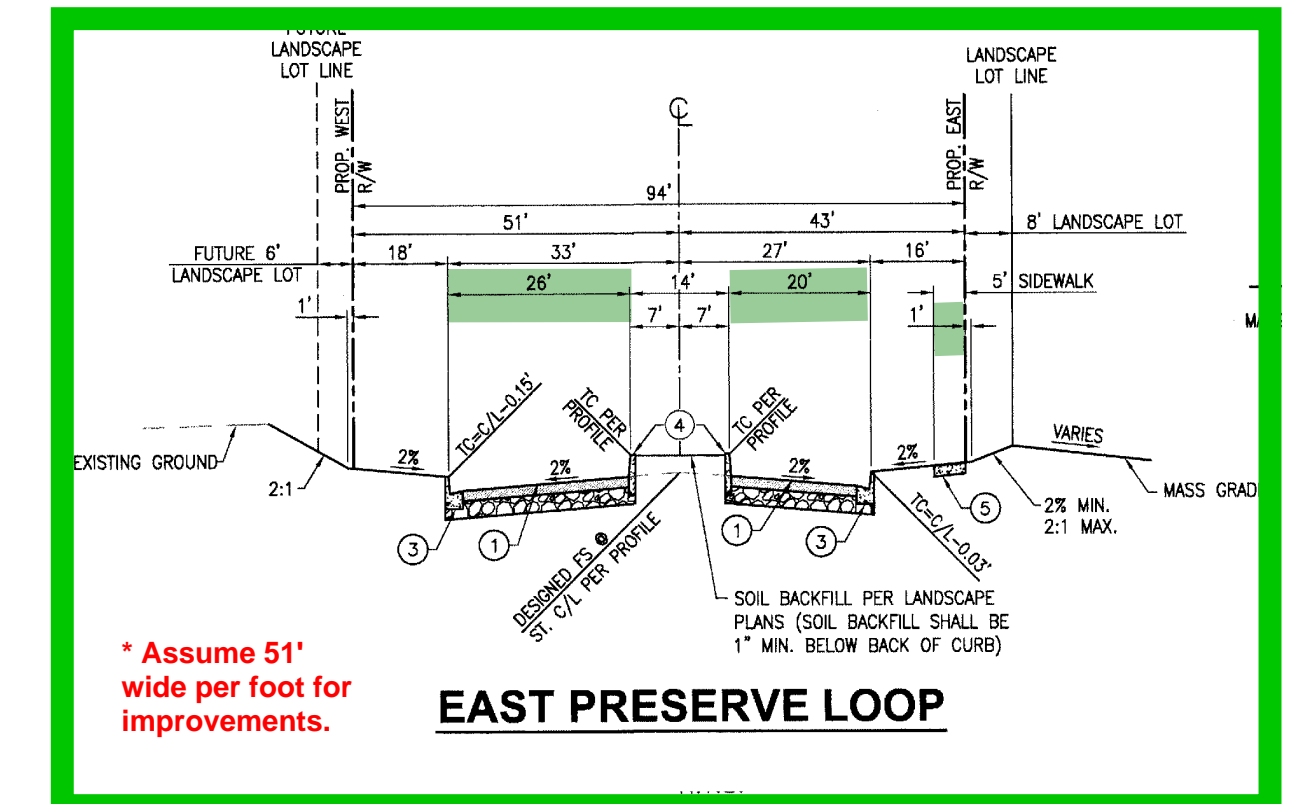

Assume 51' wide improvements:
51' x 1,440 LF = 73,440 SF

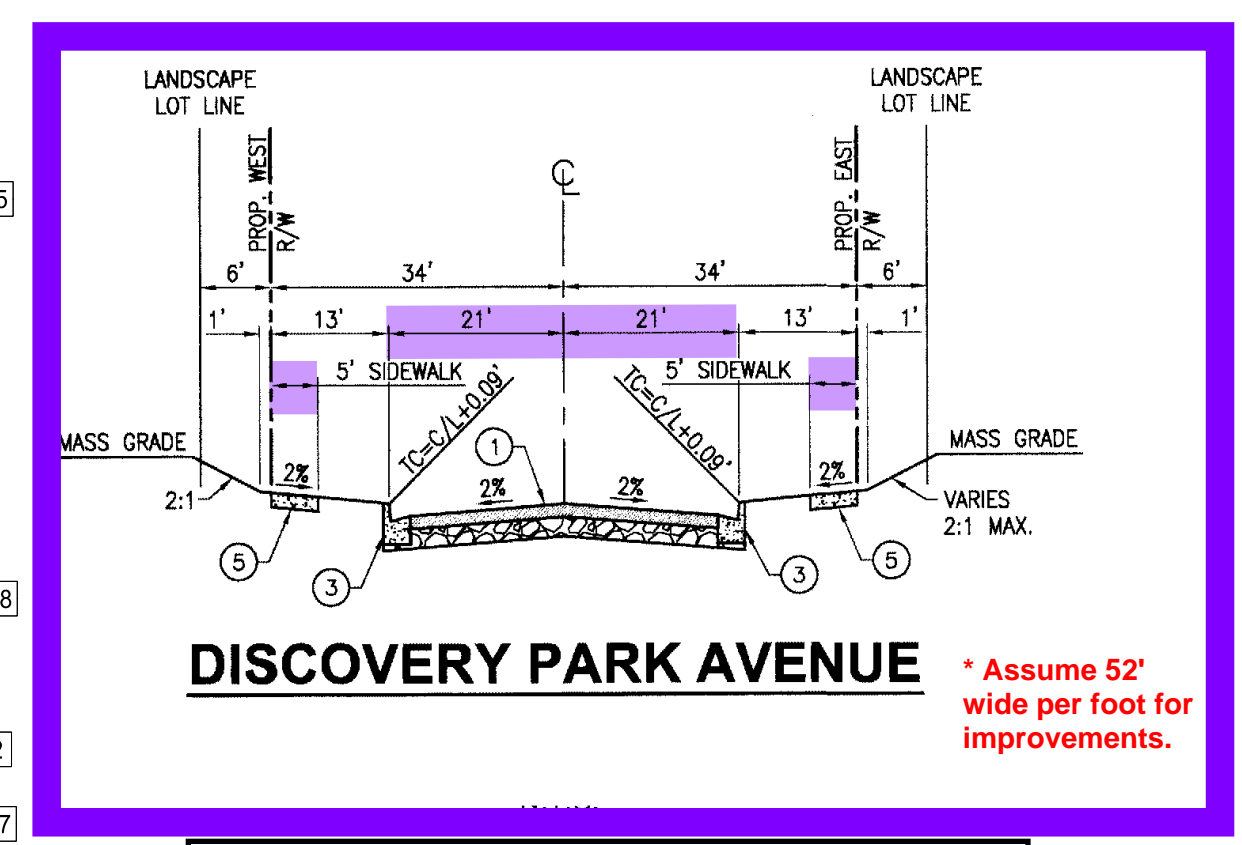

Assume 52' wide improvements:
52' x 1,823 LF = 94,796 SF

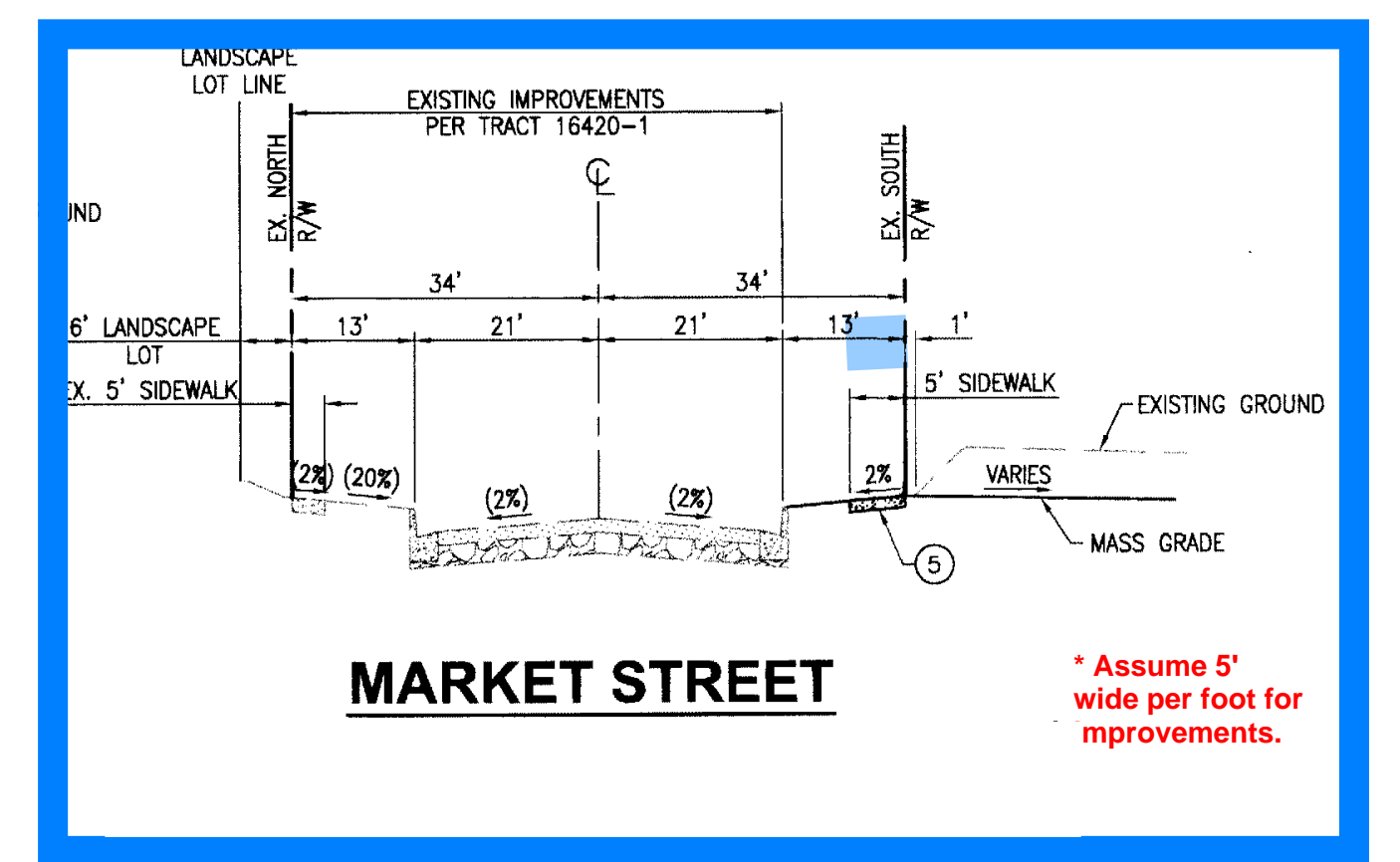

Assume 5' wide improvements:
5' x 929 LF = 4,645 SF

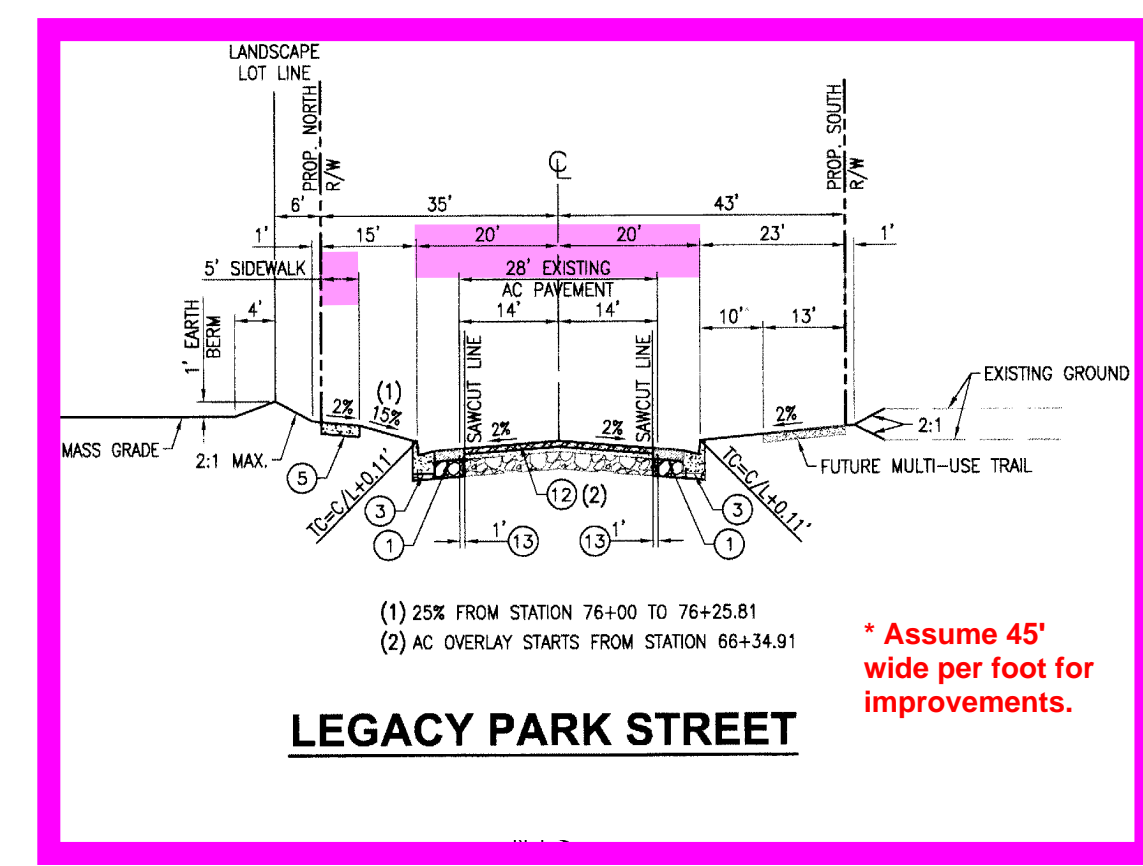

Assume 45' wide improvements:
45' x 2,402 LF = 108,090 SF

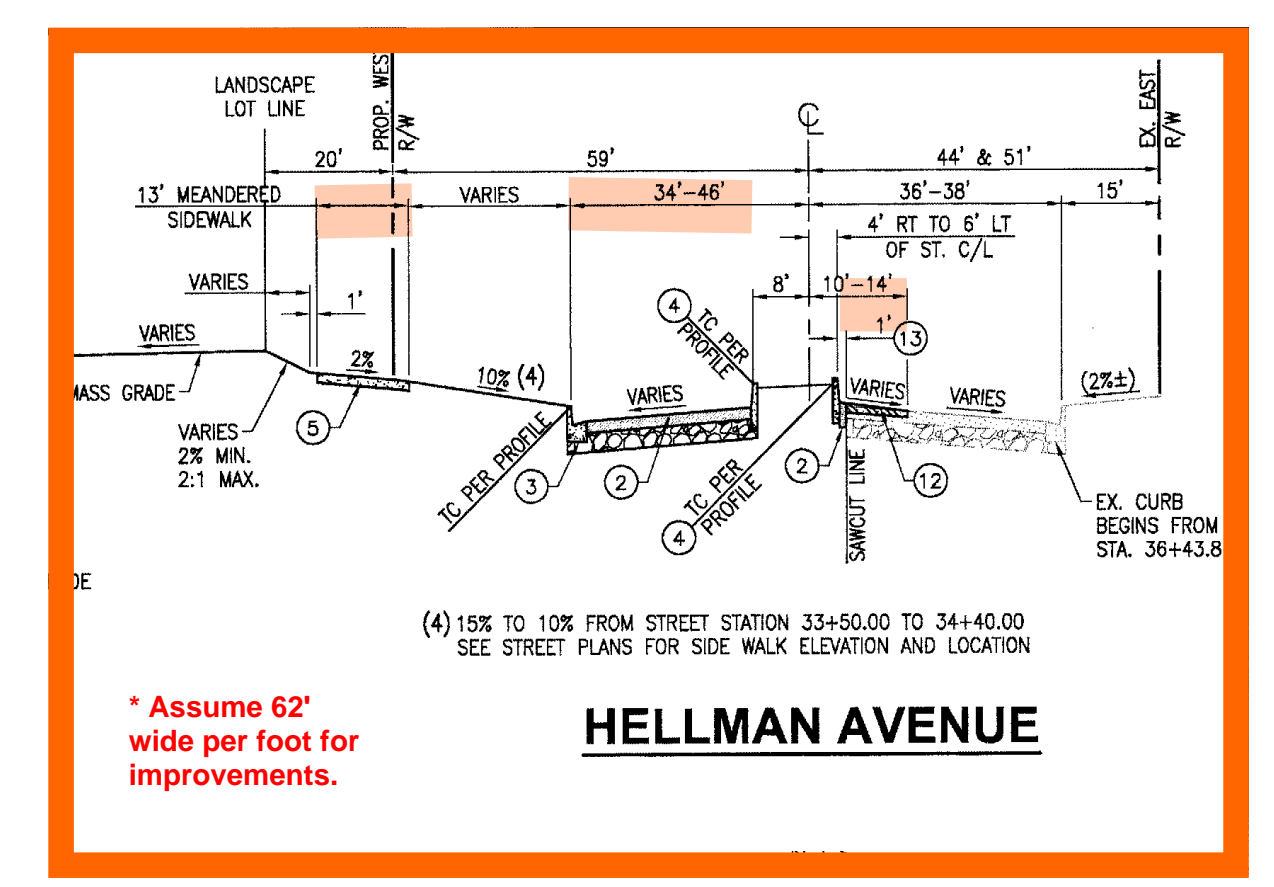

Assume 62' wide improvements:
62' x 1,805 LF = 111,910 SF

Street Name	Street SF	Total SF (All Streets)	% of Total	Total Cost (All Streets)	Total DIF Street Cost
Discovery Park Ave	94,796	392,881	24.13%	\$4,049,780.24	\$977,148.21
East Preserve Loop	73,440	392,881	18.69%	\$4,049,780.24	\$757,012.58
Hellman Ave	111,910	392,881	28.48%	\$4,049,780.24	\$1,153,557.71
Legacy Park Street	108,090	392,881	27.51%	\$4,049,780.24	\$1,114,181.51
Market Street	4,645	392,881	1.18%	\$4,049,780.24	\$47,880.22
	392,881		100.00%		\$4,049,780.24

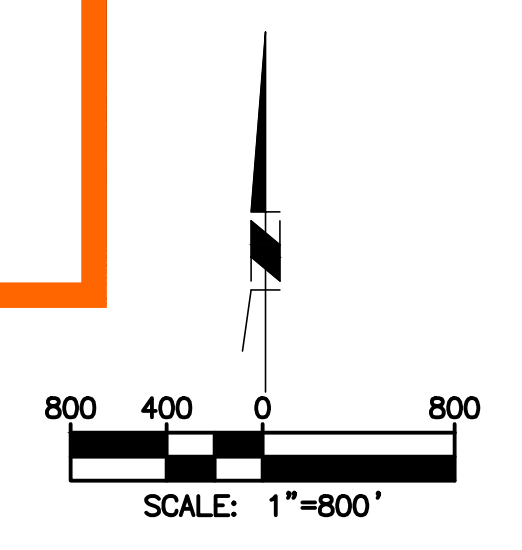

City of Chino "The Preserve" - Street DIF Tract Map No 17574

Updated 3/12/2024



CFD Streets (Kimball Ave.)

	Description	Quantity	Unit
▬	Section #1	211	ft
▬	Section #2	270	ft
▬	Section #3	856	ft

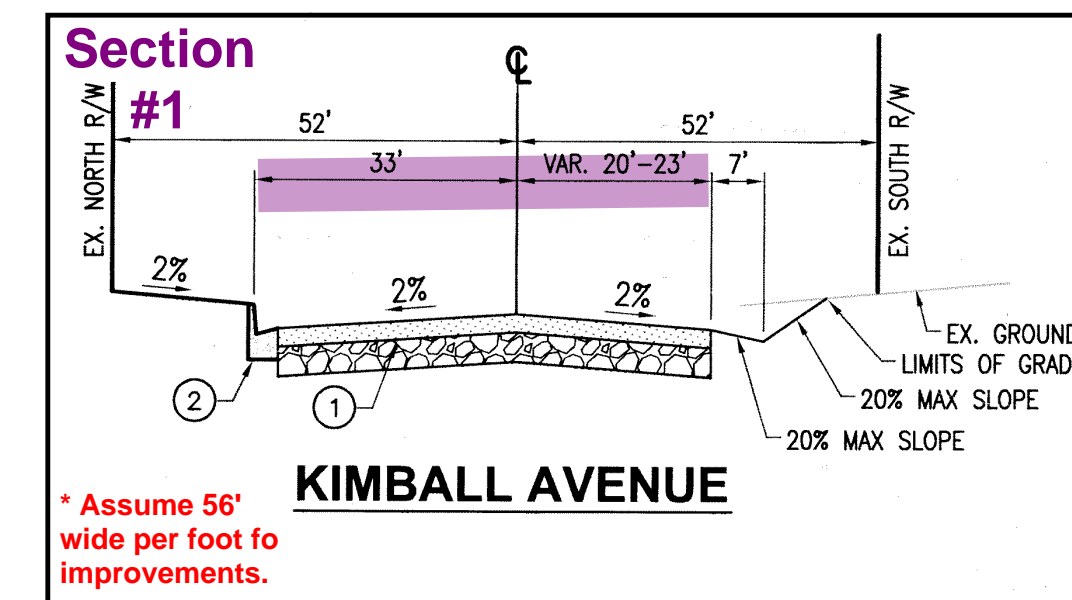

Assume 56' wide improvements:
56' x 211 LF = 11,816 SF

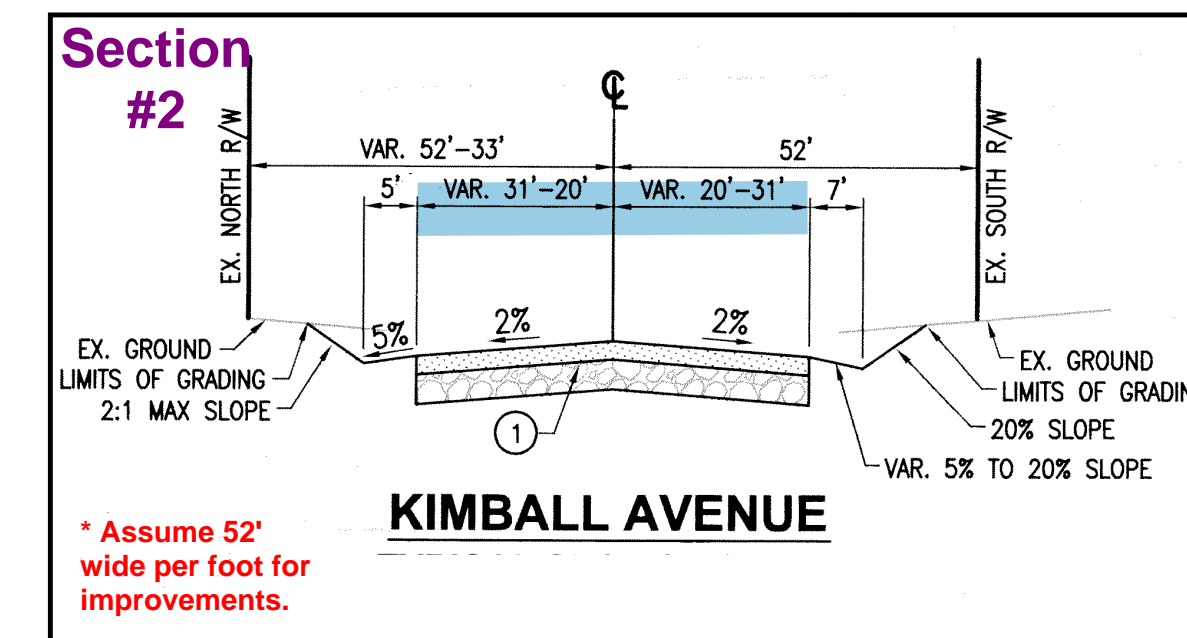

Assume 52' wide improvements:
52' x 270 LF = 14,040 SF

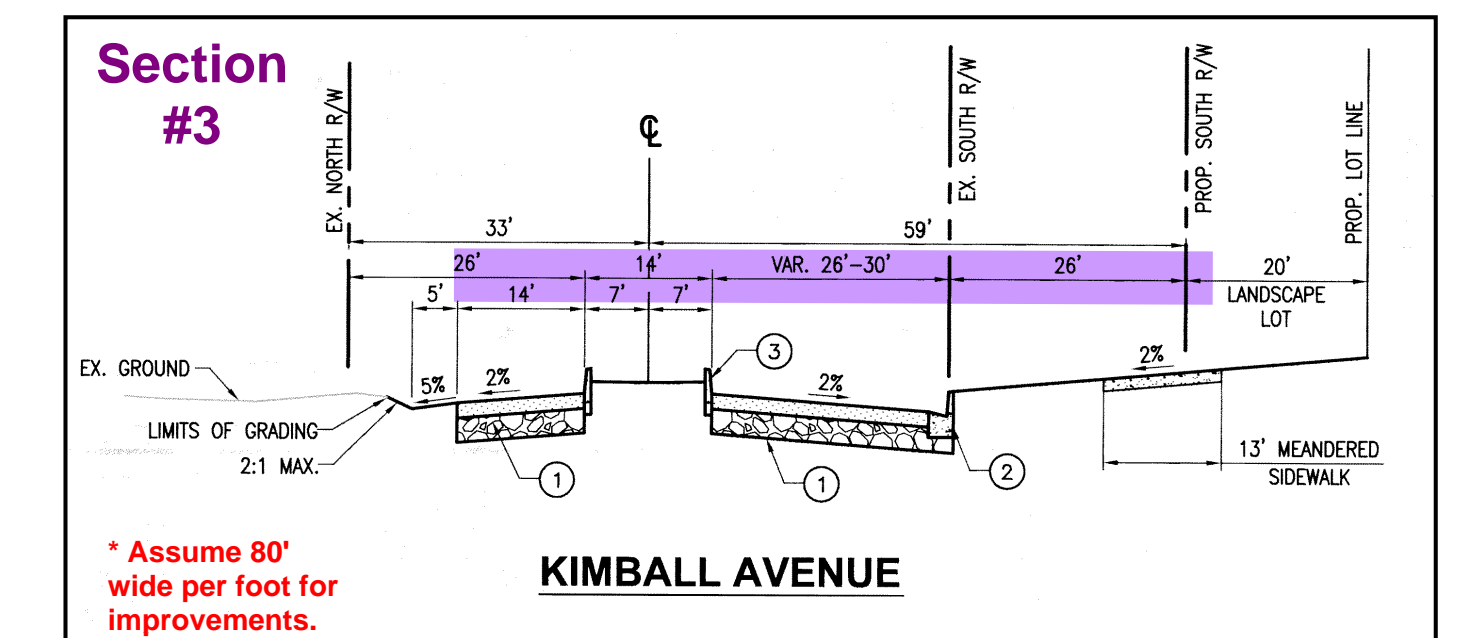

Assume 80' wide improvements:
80' x 856 LF = 68,480 SF

CFD Streets (Rincon Meadows Ave.)

	Description	Quantity	Unit
▬	Rincon Meadows Ave.	1,323	ft

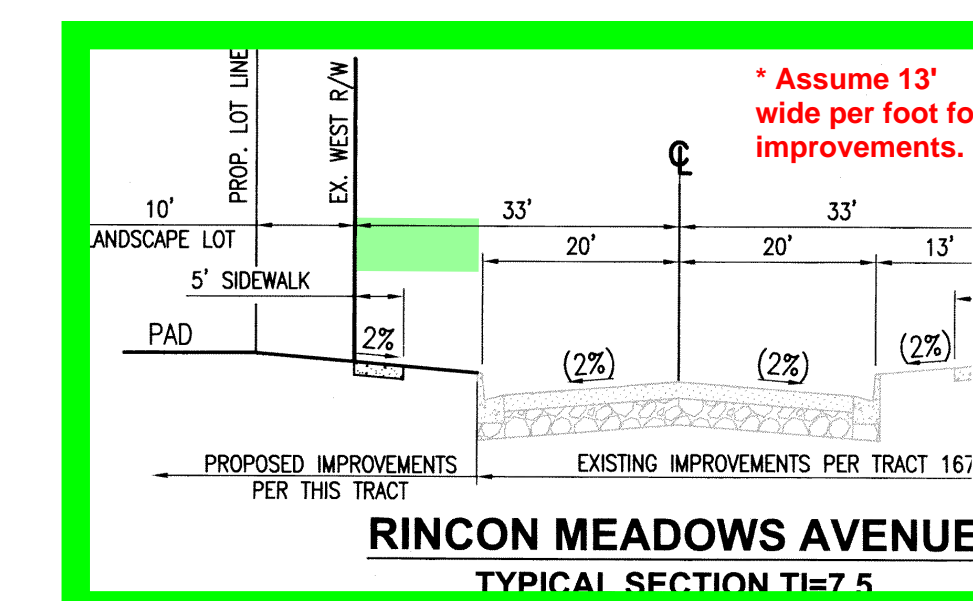

Assume 13' wide improvements:
13' x 1,323 LF = 17,199 SF

Street Name	Street SF	Total SF (All Streets)	% of Total	Total Cost (All Streets)	Total DIF Street Cost
Kimball Ave	94,336	111,535	84.58%	\$2,864,158.04	\$2,422,497.09
Rincon Meadows	17,199	111,535	15.42%	\$2,864,158.04	\$441,660.95
	111,535		100.00%		\$2,864,158.04

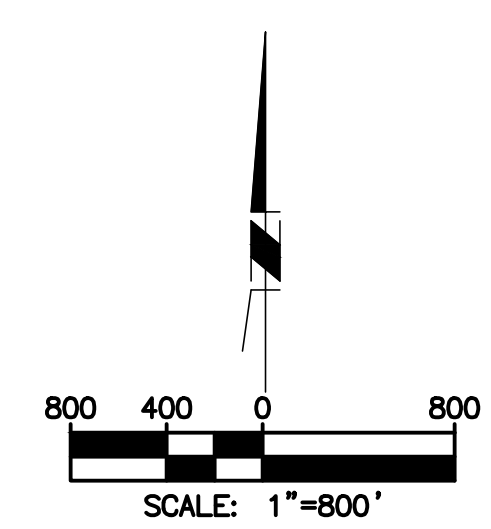

City of Chino "The Preserve" - Street DIF Tract Map No. 17571

Updated 3/12/2024

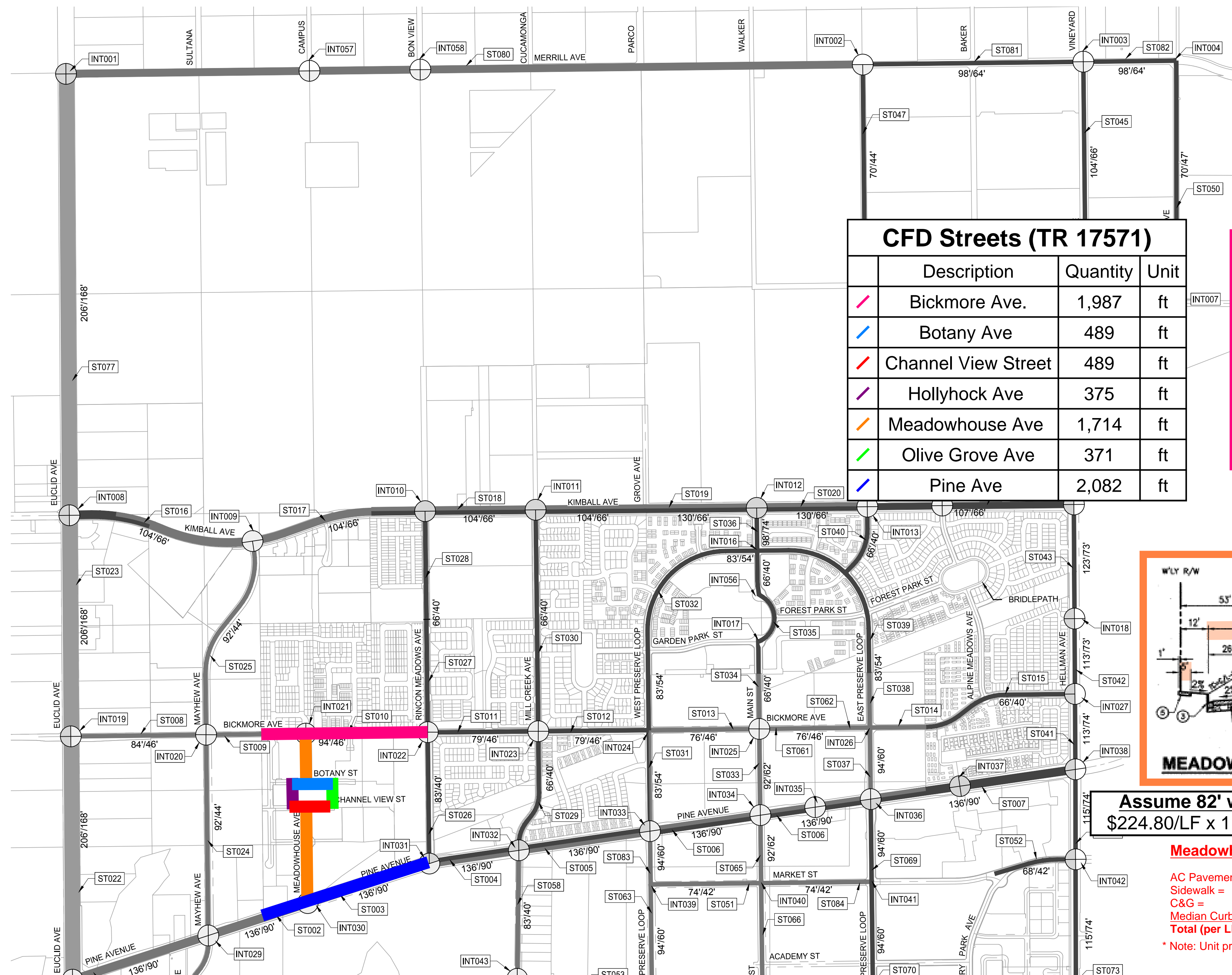

CFD Streets (TR 17571)			
	Description	Quantity	Unit
/	Bickmore Ave.	1,987	ft
/	Botany Ave	489	ft
/	Channel View Street	489	ft
/	Hollyhock Ave	375	ft
/	Meadowhouse Ave	1,714	ft
/	Olive Grove Ave	371	ft
/	Pine Ave	2,082	ft

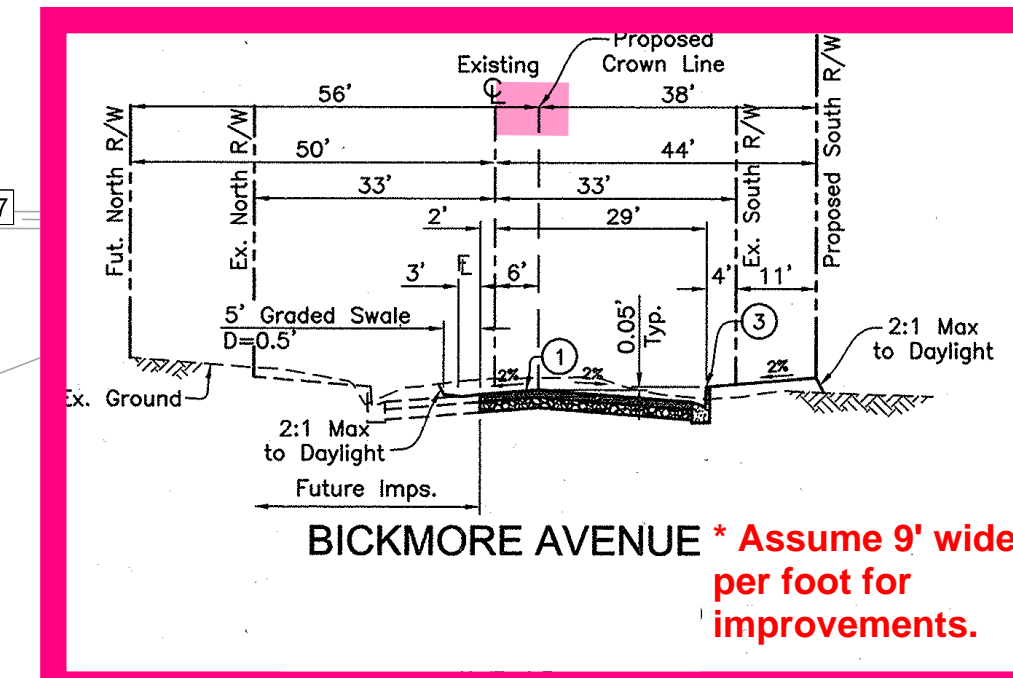

Assume 9' wide improvements:
9' x 1,987 LF = 17,883 SF

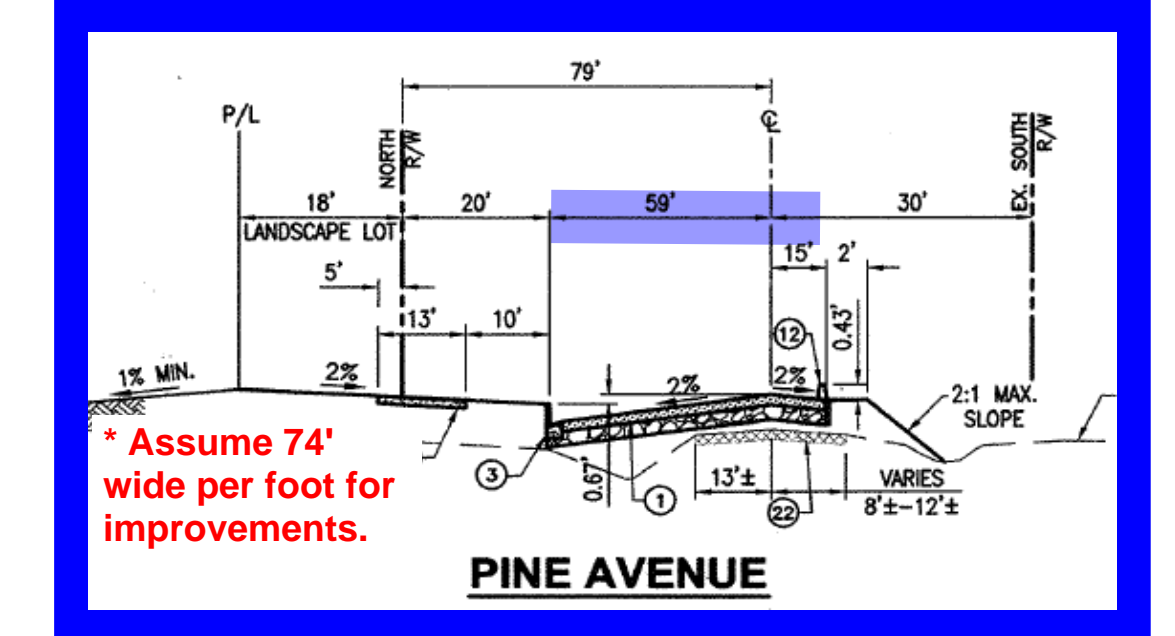

Assume 74' wide improvements:
74' x 2,082 LF = 154,068 SF

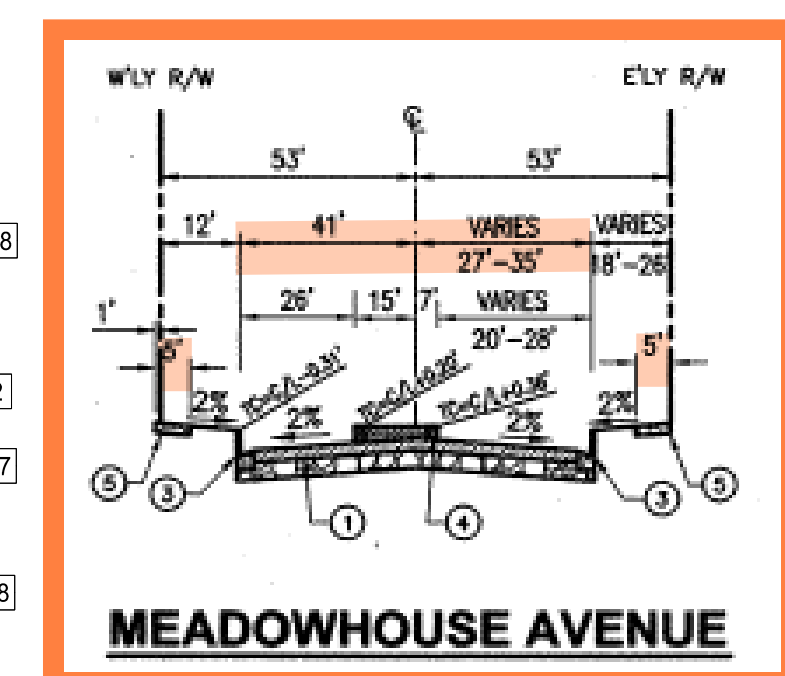

Assume 82' wide improvements:
\$224.80/LF x 1,714 LF = \$385,307.20

Meadowhouse Ave
AC Pavement = \$2.77/SF x 50' = \$138.50/LF
Sidewalk = \$3.80/SF x 10' = \$38.00/LF
C&G = \$15.75/LF x 2' = \$31.50/LF
Median Curb = \$8.40/LF x 2' = \$16.80/LF
Total (per LF of Road) = 224.80/LF
* Note: Unit prices per CFD contract

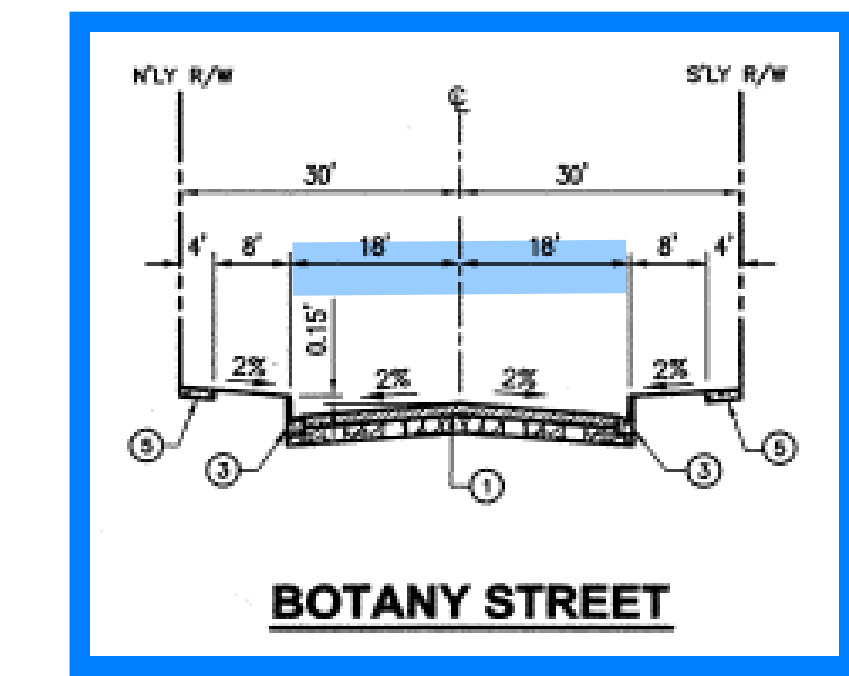

Assume 36' wide improvements:
\$120.14/LF x 489 LF = \$58,748.46

Botany Street
AC Pavement = \$2.77/SF x 32' = \$88.64/LF
C&G = \$15.75/LF x 2' = \$31.50/LF
Total (per LF of Road) = 120.14/LF
* Note: Unit prices per CFD contract

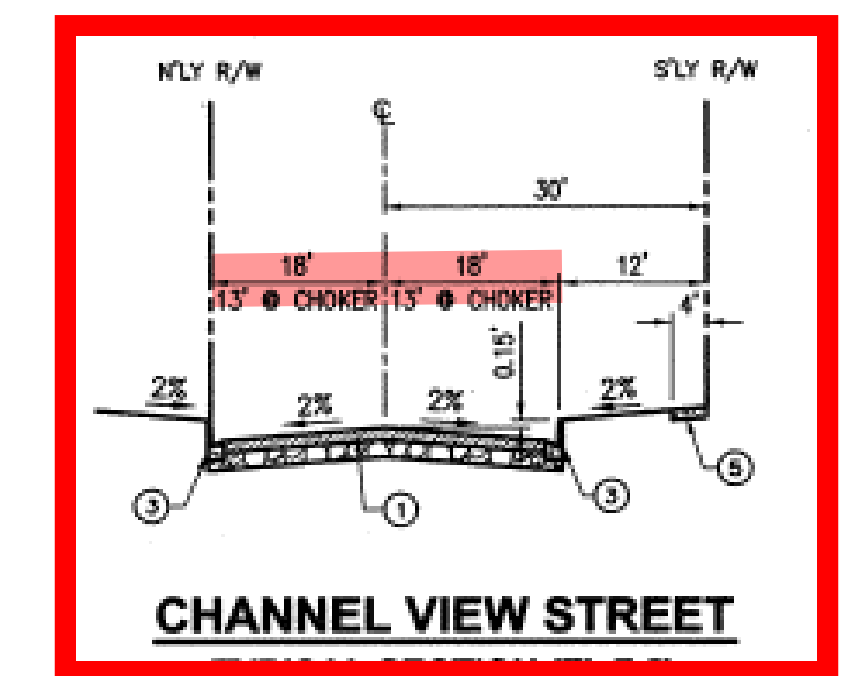

Assume 36' wide improvements:
\$120.14/LF x 489 LF = \$58,748.46

Channel View Street
AC Pavement = \$2.77/SF x 32' = \$88.64/LF
C&G = \$15.75/LF x 2' = \$31.50/LF
Total (per LF of Road) = 120.14/LF
* Note: Unit prices per CFD contract

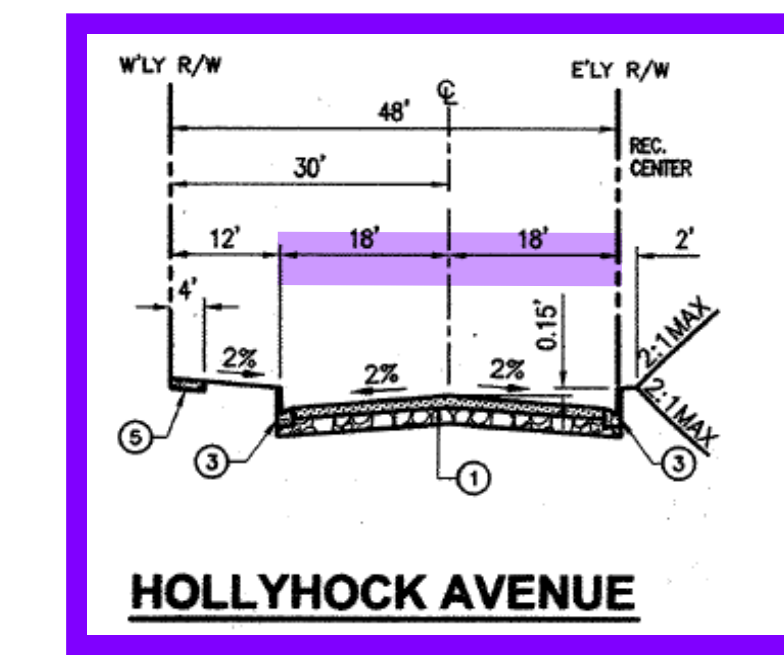

Assume 36' wide improvements:
\$120.14/LF x 375 LF = \$45,052.50 SF

Hollyhock Ave
AC Pavement = \$2.77/SF x 32' = \$88.64/LF
C&G = \$15.75/LF x 2' = \$31.50/LF
Total (per LF of Road) = 120.14/LF
* Note: Unit prices per CFD contract

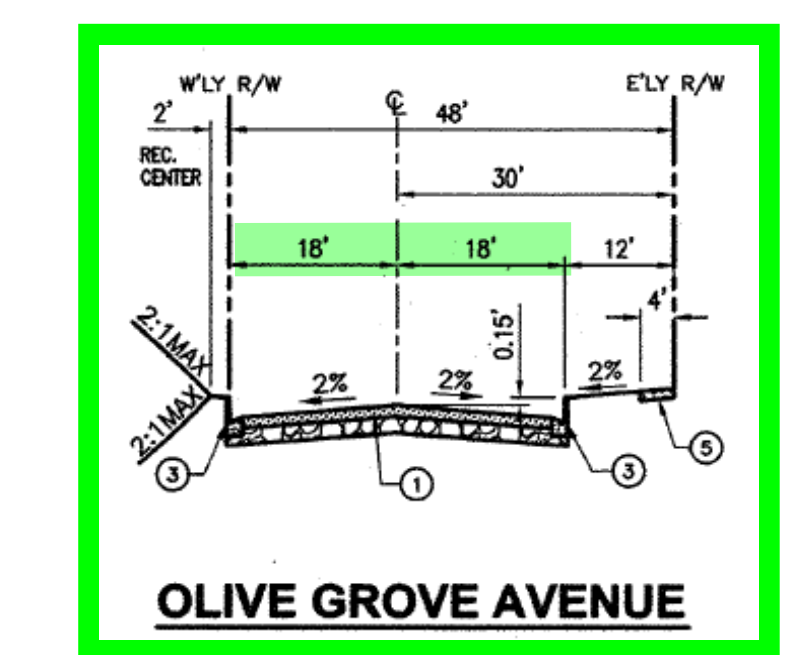

Assume 36' wide improvements:
\$120.14/LF x 371 LF = \$44,571.95

Olive Grove Ave
AC Pavement = \$2.77/SF x 32' = \$88.64/LF
C&G = \$15.75/LF x 2' = \$31.50/LF
Total (per LF of Road) = 120.14/LF
* Note: Unit prices per CFD contract

Street Name	Street SF	Total SF (All Streets)	% of Total	Total DIF Cost (All Streets)	Street Cost	Total DIF Street Cost
Street Cost						\$ 1,669,154.11
B/CV/HH/MH/OG Street Lights						\$ (324,465.38)
B/CV/HH/MH/OG Streetscape						\$ (226,965.35)
Botany Ave						\$ (58,748.46)
Channel View St						\$ (58,748.46)
Hollyhock Ave						\$ (45,052.50)
Meadowhouse Ave						\$ (385,307.20)
Olive Grove Ave						\$ (44,571.95)
DIF Street Total						\$ 525,294.81
Bickmore Ave	17,883	171,951	10.40%	\$525,294.81		\$54,630.95
Pine Ave	154,068	171,951	89.60%	\$525,294.81		\$470,663.86
	171,951		100.00%			\$525,294.81

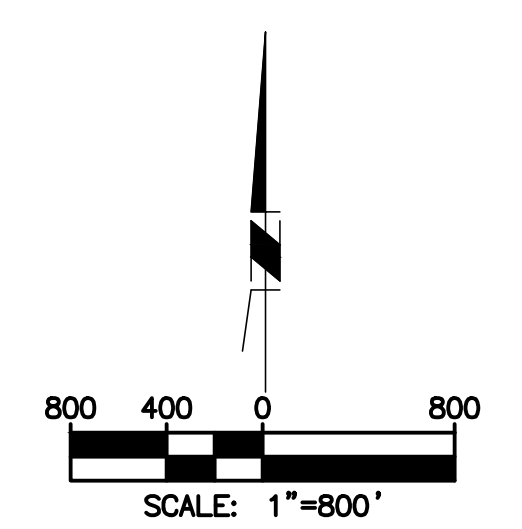

City of Chino "The Preserve" - Street DIF Tract Map No. 16419

Updated 3/12/2024

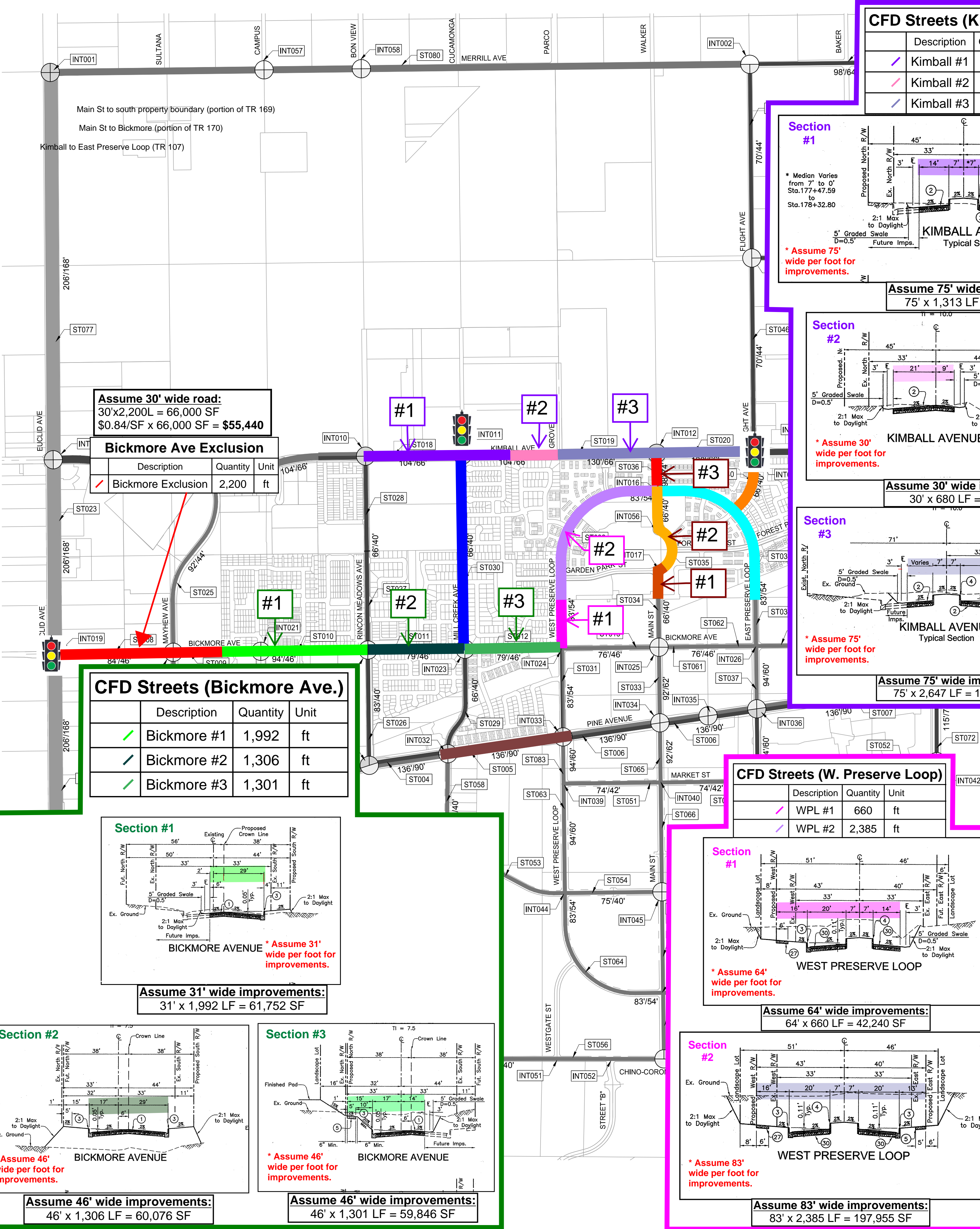

CFD Streets (Kimball Ave.)

Description	Quantity	Unit
Kimball #1	1,995	ft
Kimball #2	680	ft
Kimball #3	2,647	ft

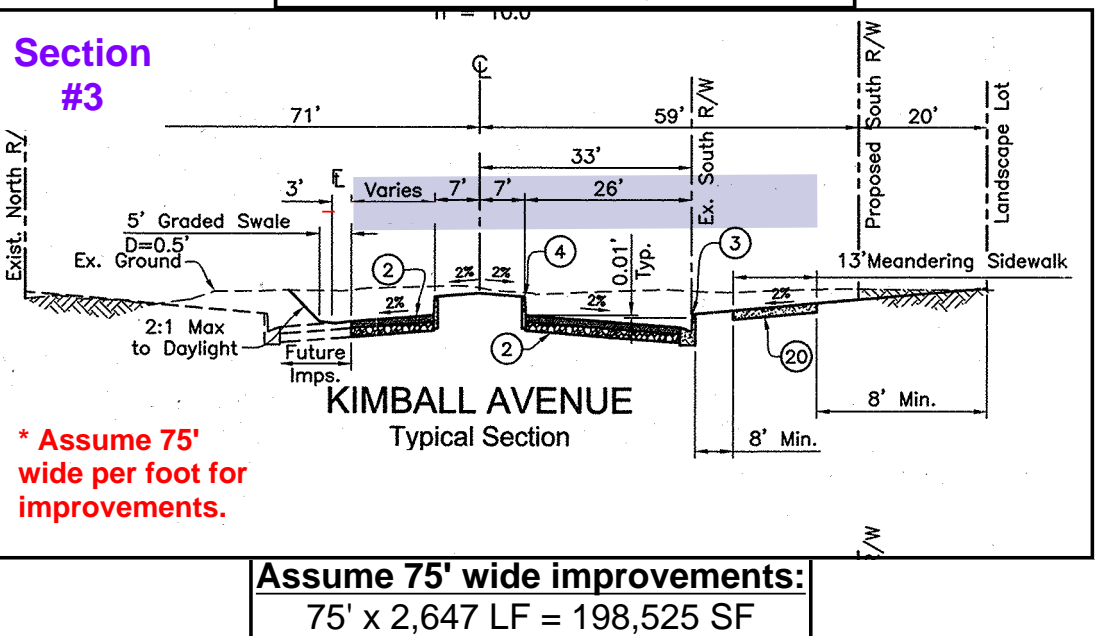
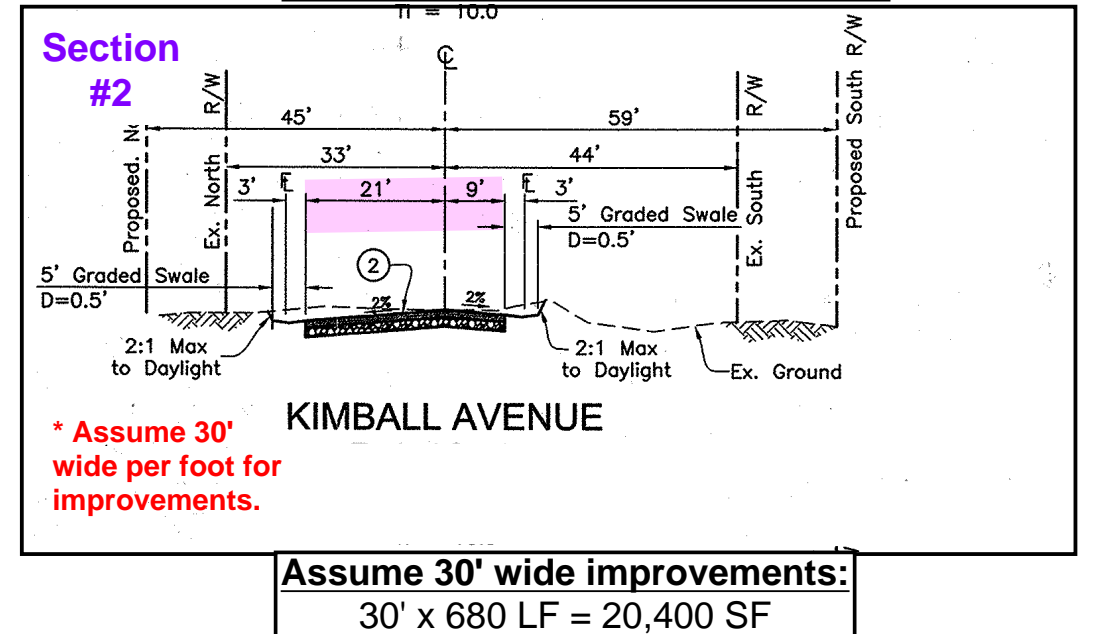
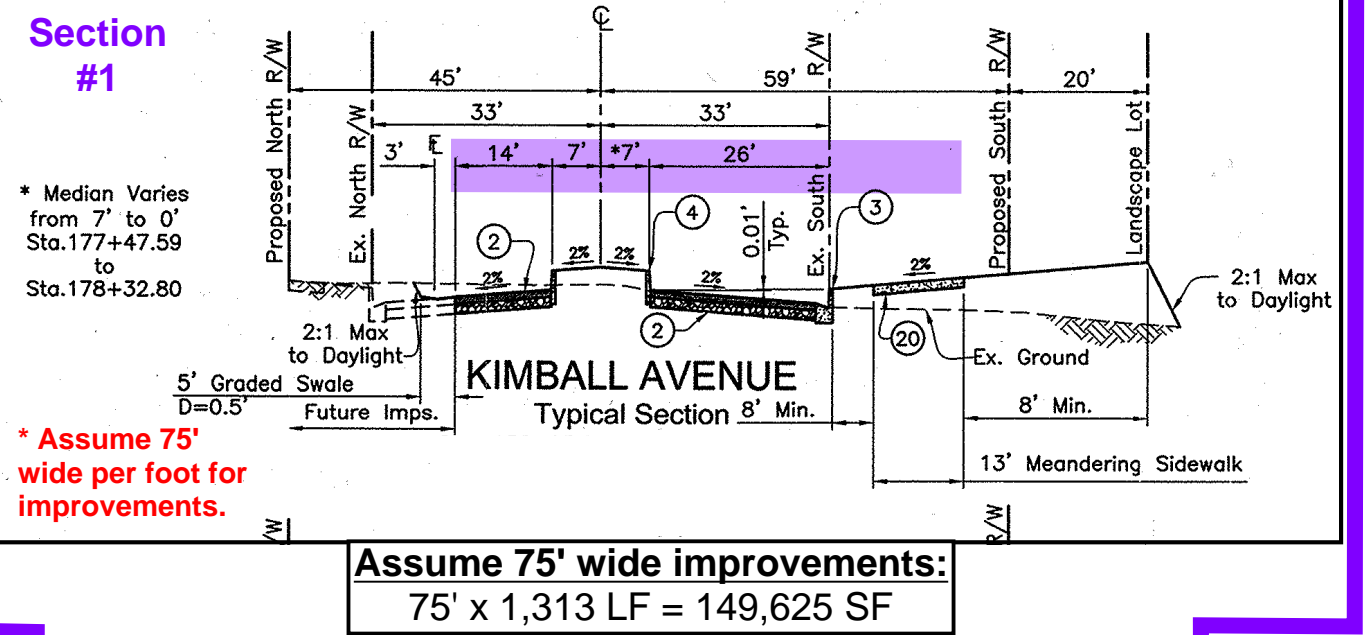

CFD Streets (W. Preserve Loop)

Description	Quantity	Unit
WPL #1	660	ft
WPL #2	2,385	ft

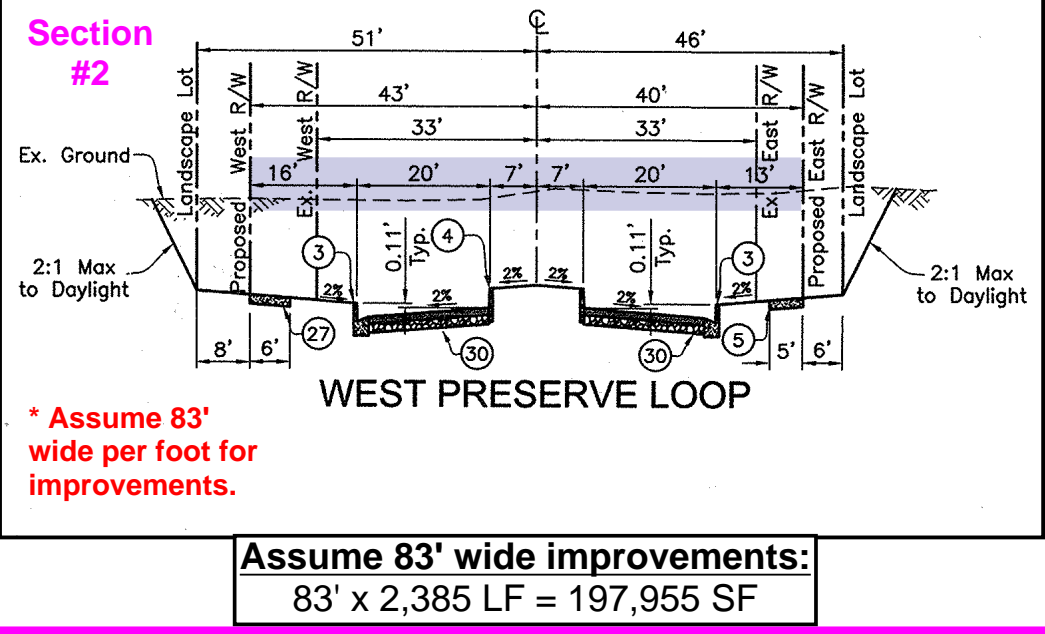
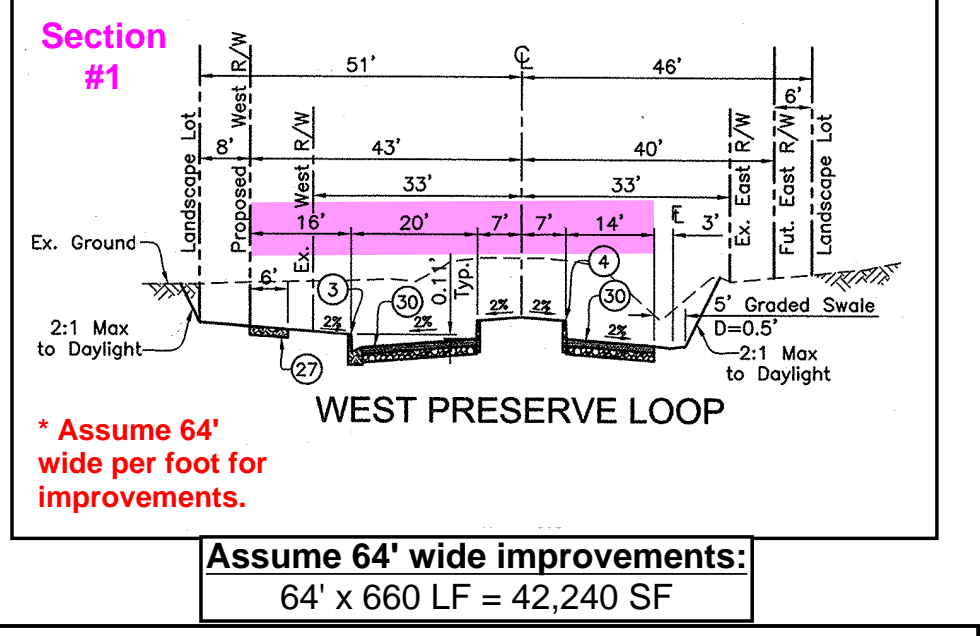

CFD Streets (Main St.)

Description	Quantity	Unit
Main #1	484	ft
Main #2	1,199	ft
Main #3	440	ft

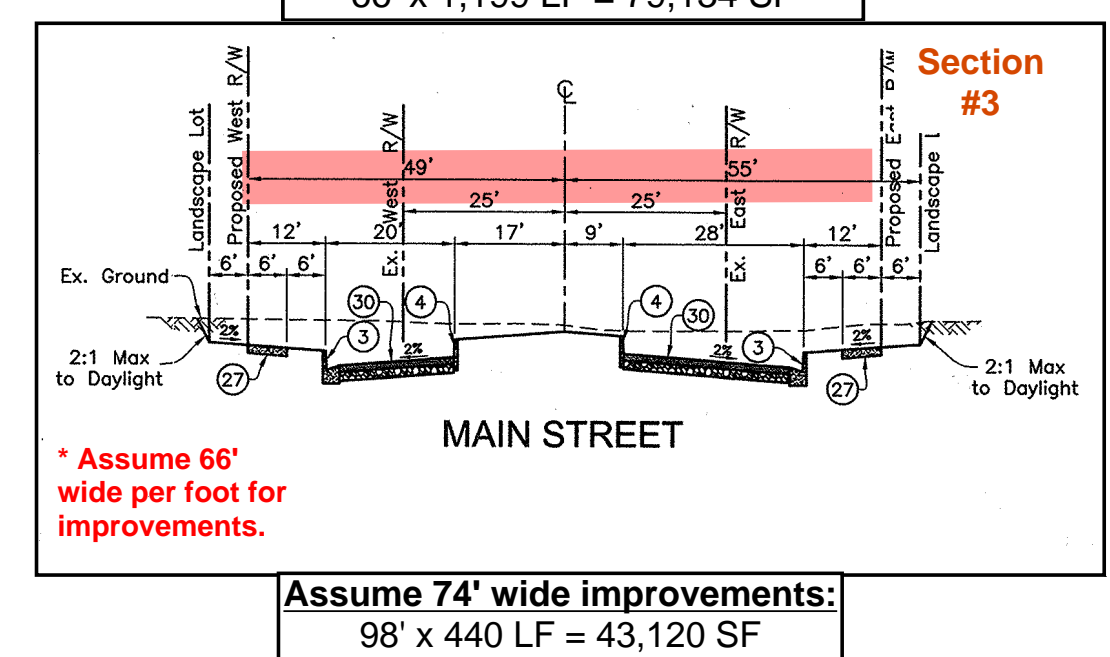
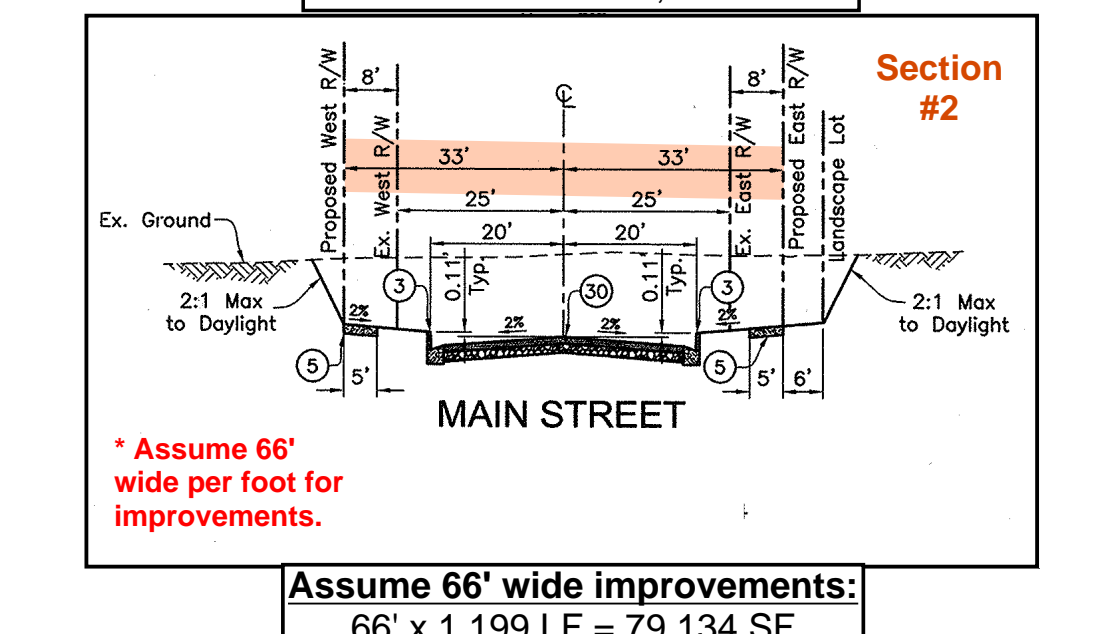
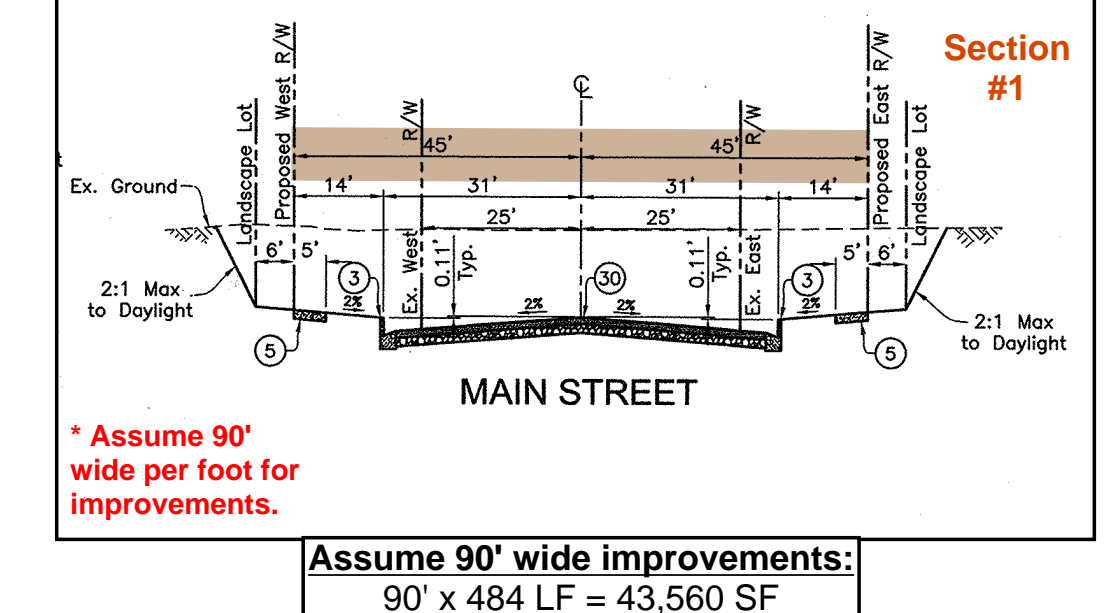

CFD Streets & Signals Ph. 1

Description	Quantity	Unit
E. Preserve Loop	2,386	ft
Flight Ave.	874	ft
Mill Creek Ave.	2,641	ft
Pine Ave.	1,801	ft

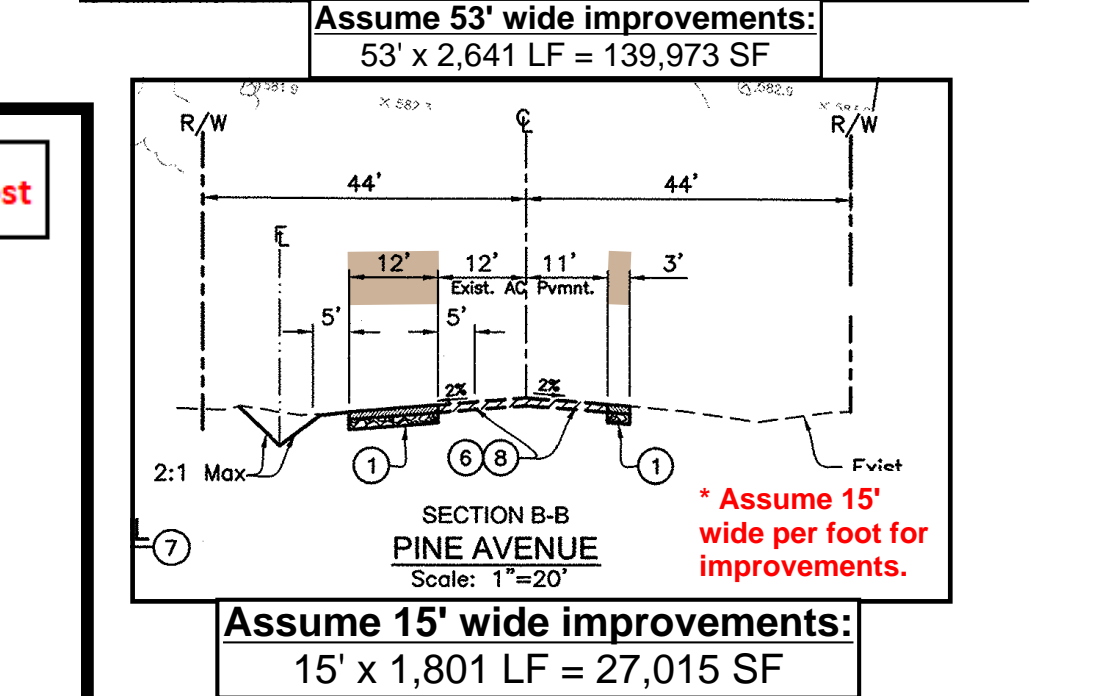
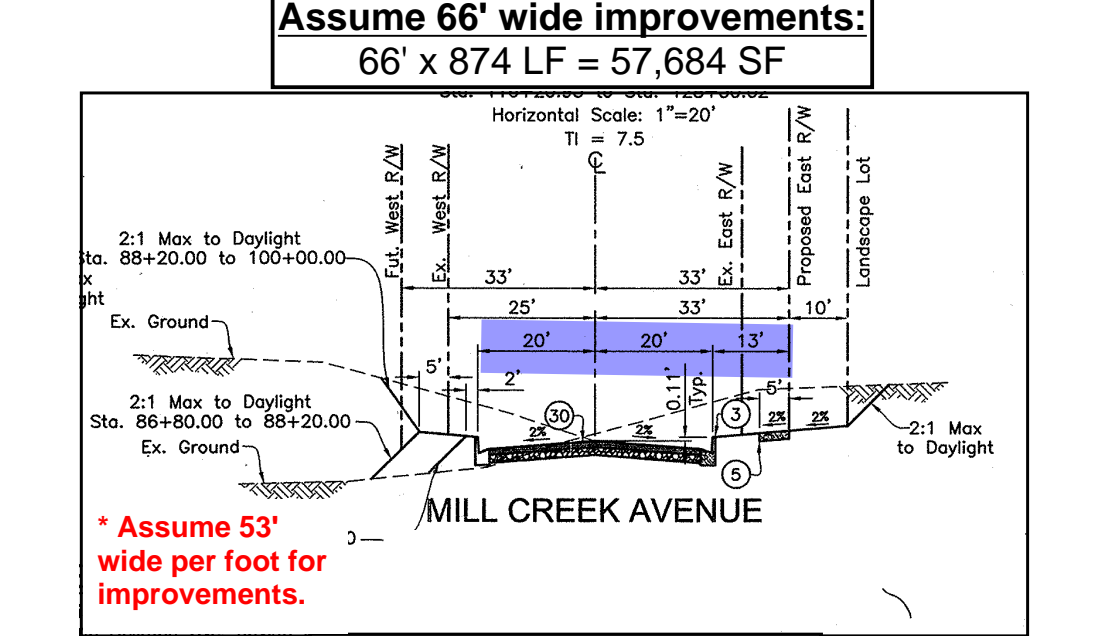
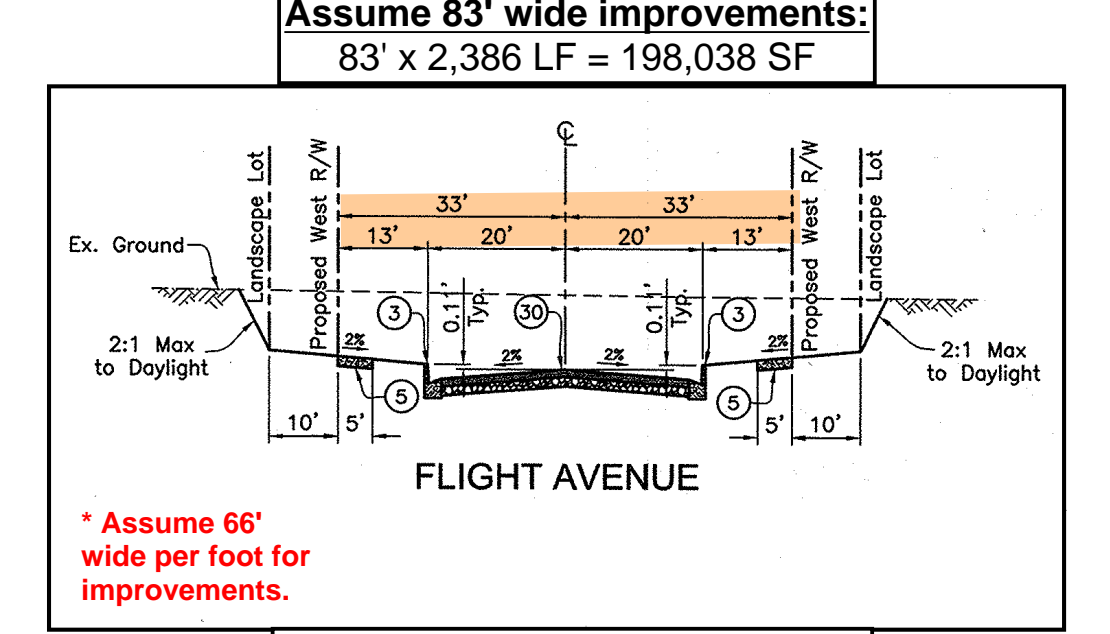
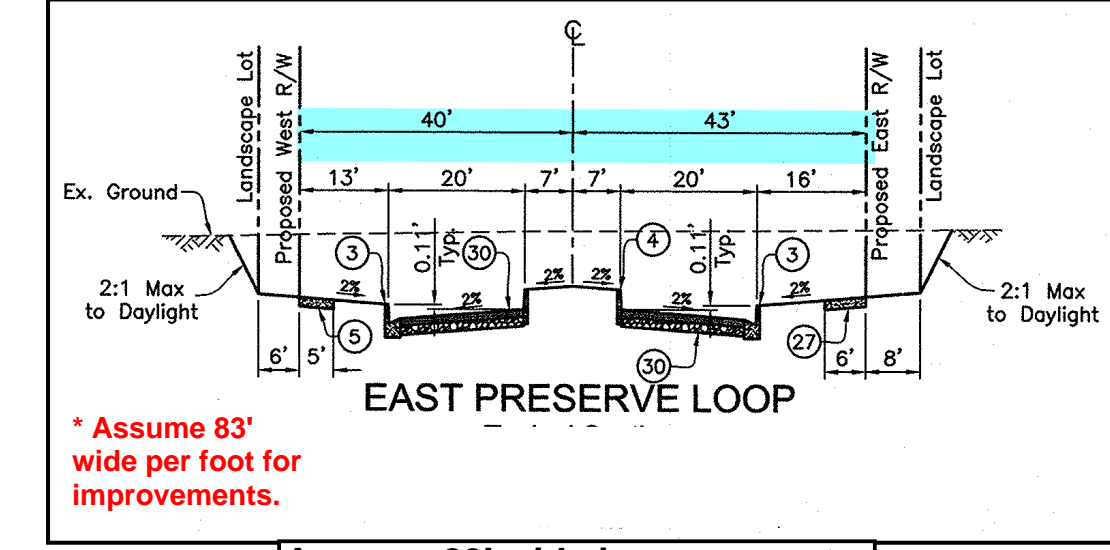

Street Name	Street SF	Total SF (All Streets)	% of Total	Total Cost (All Streets)	Total DIF Street Cost
Bickmore Ave #1	61,752	1,378,943	4.48%	\$10,446,878.99	\$467,833.46
Bickmore Ave #2	60,076	1,378,943	4.36%	\$10,446,878.99	\$455,136.07
Bickmore Ave #3	59,846	1,378,943	4.34%	\$10,446,878.99	\$453,393.59
Kimball Ave #1	149,625	1,378,943	10.85%	\$10,446,878.99	\$1,133,559.74
Kimball Ave #2	20,400	1,378,943	1.48%	\$10,446,878.99	\$154,550.50
Kimball Ave #3	198,525	1,378,943	14.40%	\$10,446,878.99	\$1,504,026.38
West Preserve Loop #1	42,240	1,378,943	3.06%	\$10,446,878.99	\$320,010.45
West Preserve Loop #2	197,955	1,378,943	14.36%	\$10,446,878.99	\$1,499,708.06
Main Street #1	43,560	1,378,943	3.16%	\$10,446,878.99	\$330,010.78
Main Street #2	79,134	1,378,943	5.74%	\$10,446,878.99	\$599,519.58
Main Street #3	43,120	1,378,943	3.13%	\$10,446,878.99	\$326,677.33
East Preserve Loop	198,038	1,378,943	14.36%	\$10,446,878.99	\$1,500,336.87
Flight Ave	57,684	1,378,943	4.18%	\$10,446,878.99	\$437,014.27
Mill Creek Ave	139,973	1,378,943	10.15%	\$10,446,878.99	\$1,060,436.14
Pine Ave	27,015	1,378,943	1.96%	\$10,446,878.99	\$204,665.77
TOTAL	1,378,943	1,378,943	100.00%	\$10,446,878.99	\$10,446,878.99

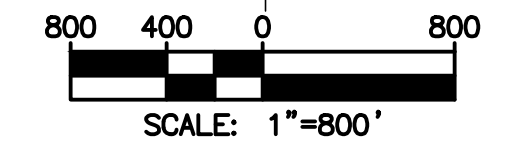

City of Chino "The Preserve" - Street DIF Tracts 16419, 17057 & 17571

Updated 3/12/2024

Description	Quantity	Unit
Alpine Meadows Ave	1,294	ft
Bicmore #3	1,744	ft
Forest Park St.	865	ft
Hellman Ave.	745	ft
Kimball Ave	2,371	ft
Meadow Valley Ave.	724	ft
Mill Creek Ave	1,356	ft
Rincon Meadows Ave	1,456	ft

Description	Quantity	Unit
Pine #1	2,053	ft
Pine #2	1,806	ft

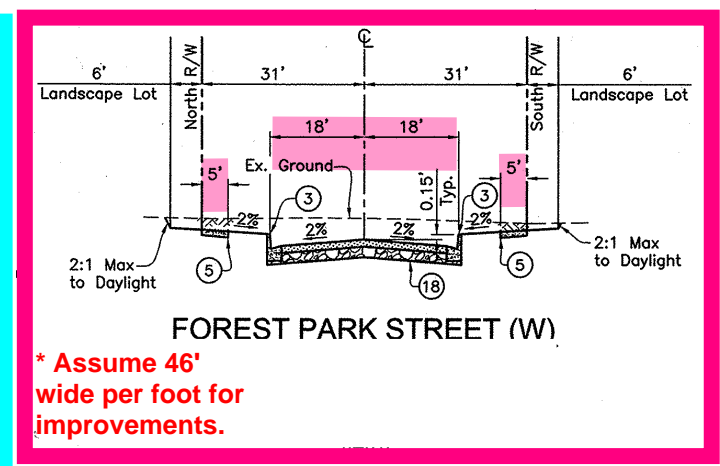
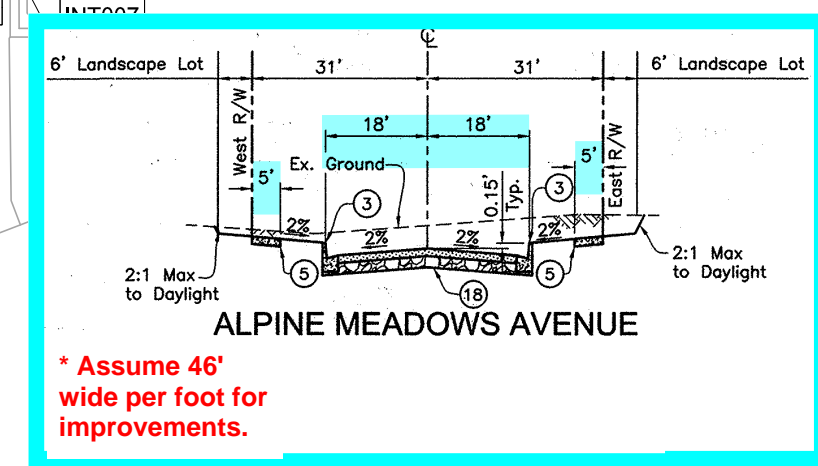
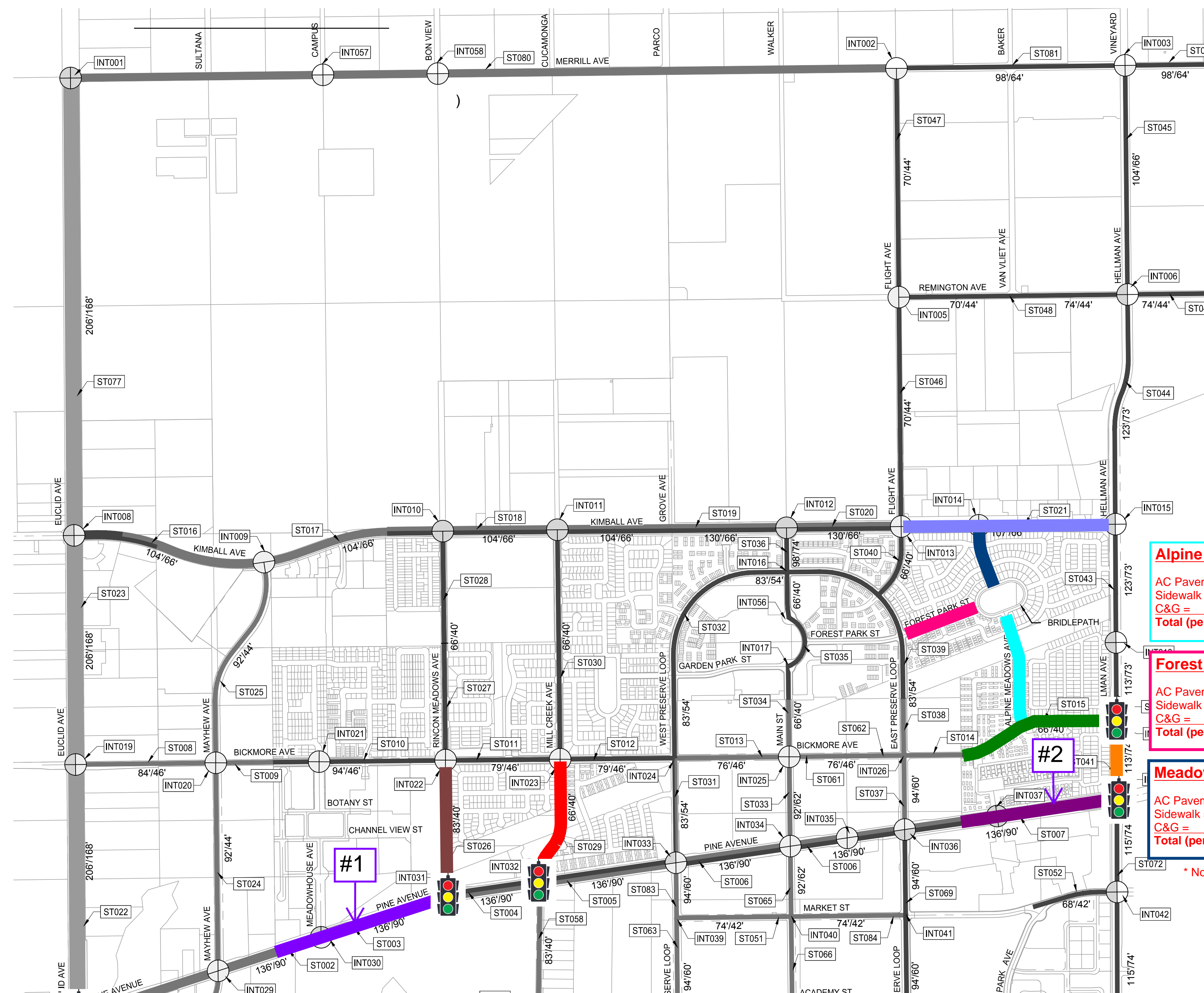

Assume 46' wide improvements:
\$157.30/LF x 1,294 LF = \$203,546.20

Assume 46' wide improvements:
\$157.30/LF x 865 LF = \$136,064.50

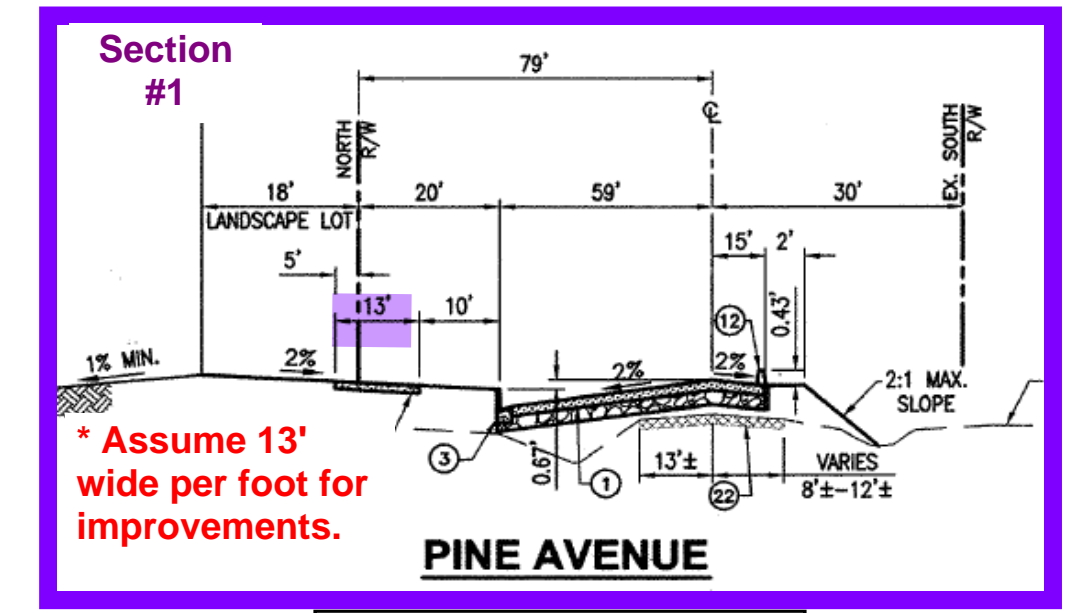

Assume 13' wide improvements:
13' x 2,053 LF = 26,689 SF

Alpine Meadows Ave
AC Pavement = \$2.75/SF x 32' = \$88.00/LF
Sidewalk = \$3.30/SF x 10 = \$33.30/LF
C&G = \$18/LF x 2 = \$36.00/LF
Total (per LF of Road) = 157.30/LF

Forest Park Street
AC Pavement = \$2.75/SF x 32' = \$88.00/LF
Sidewalk = \$3.30/SF x 10 = \$33.30/LF
C&G = \$18/LF x 2 = \$36.00/LF
Total (per LF of Road) = 157.30/LF

Meadow Valley Ave
AC Pavement = \$2.75/SF x 32' = \$88.00/LF
Sidewalk = \$3.30/SF x 10 = \$33.30/LF
C&G = \$18/LF x 2 = \$36.00/LF
Total (per LF of Road) = 157.30/LF

* Note: Unit prices per CFD contract

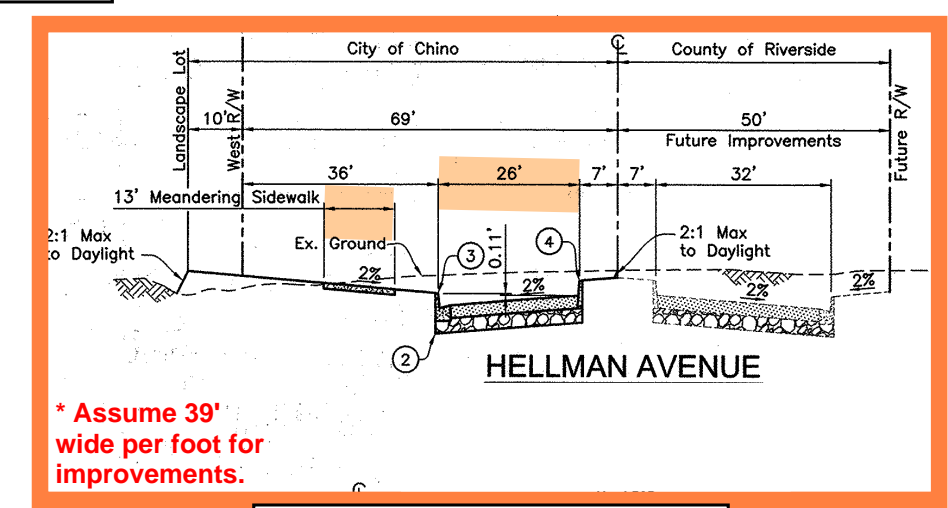

Assume 39' wide improvements:
39' x 745 LF = 29,055 SF

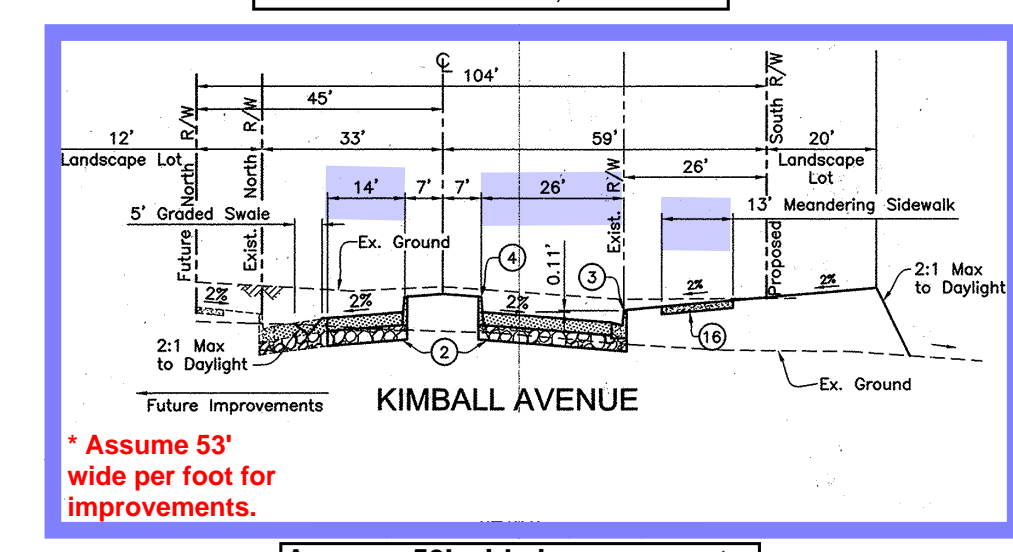

Assume 53' wide improvements:
53' x 2,371 LF = 125,663 SF

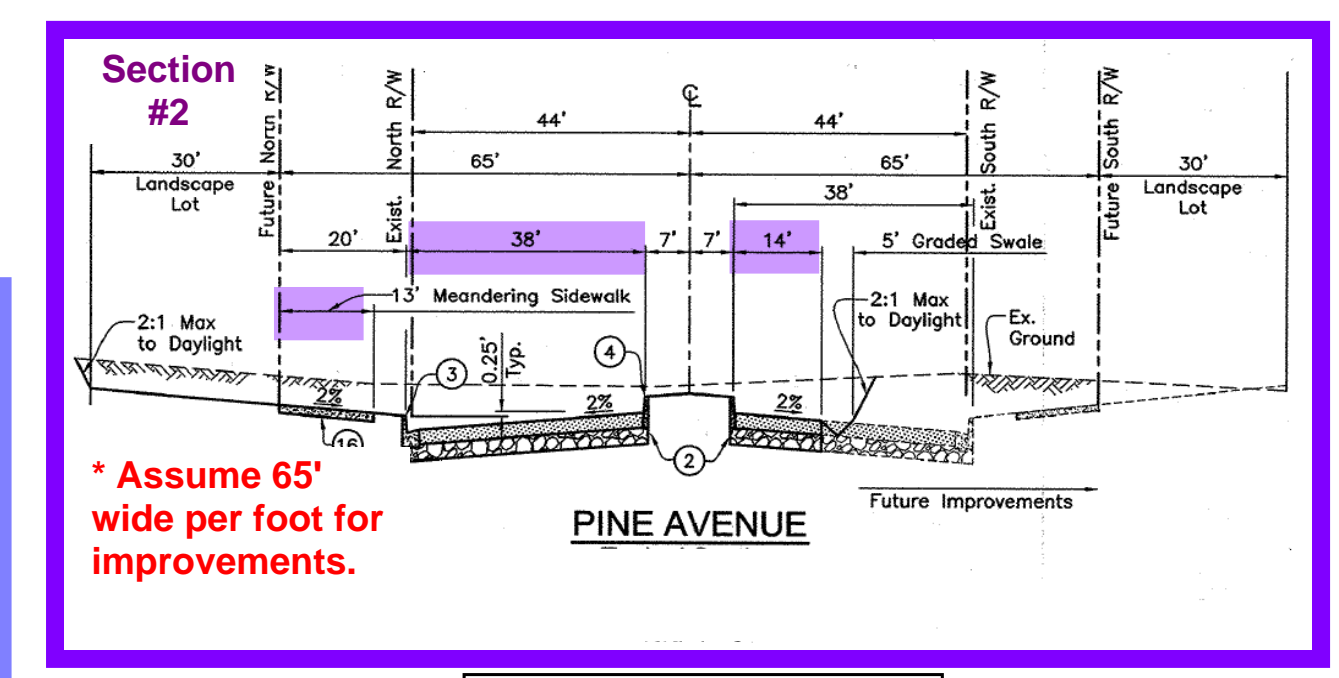

Assume 65' wide improvements:
65' x 1,806 LF = 117,390 SF

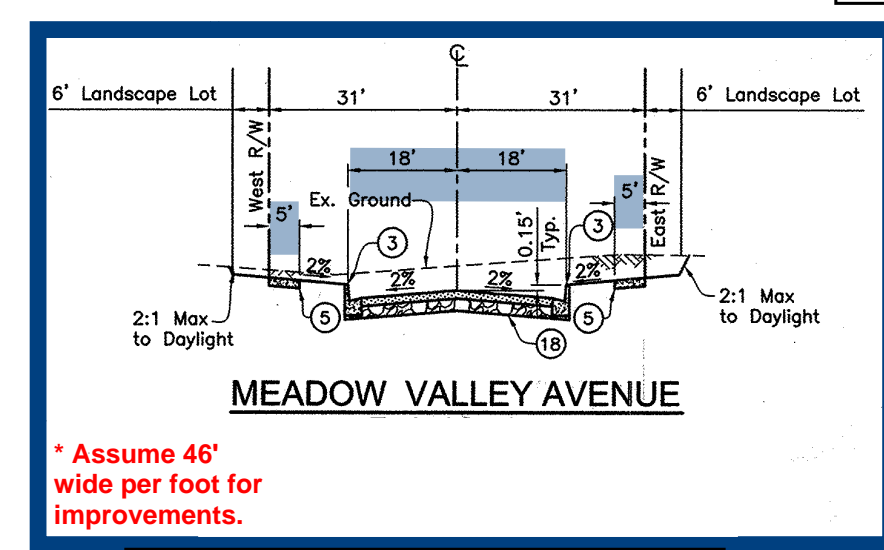

Assume 46' wide improvements:
\$157.30/LF x 724 LF = \$113,885.20

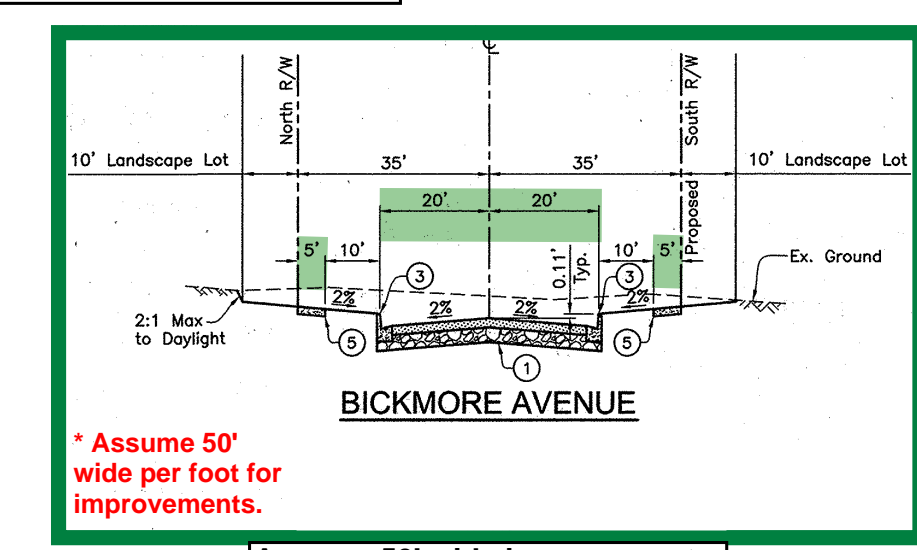

Assume 50' wide improvements:
50' x 1,744 LF = 87,200 SF

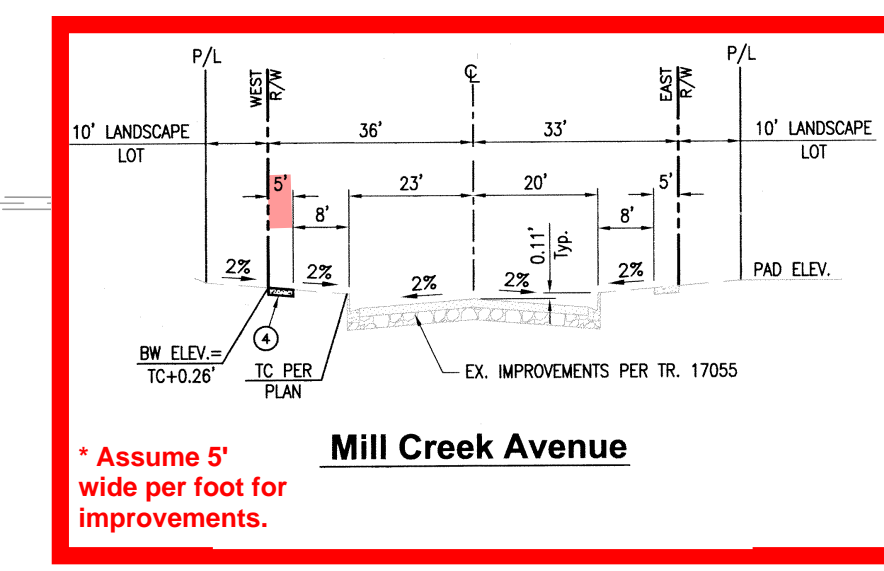

Assume 13' wide improvements:
5' x 1,356 LF = 6,780 SF

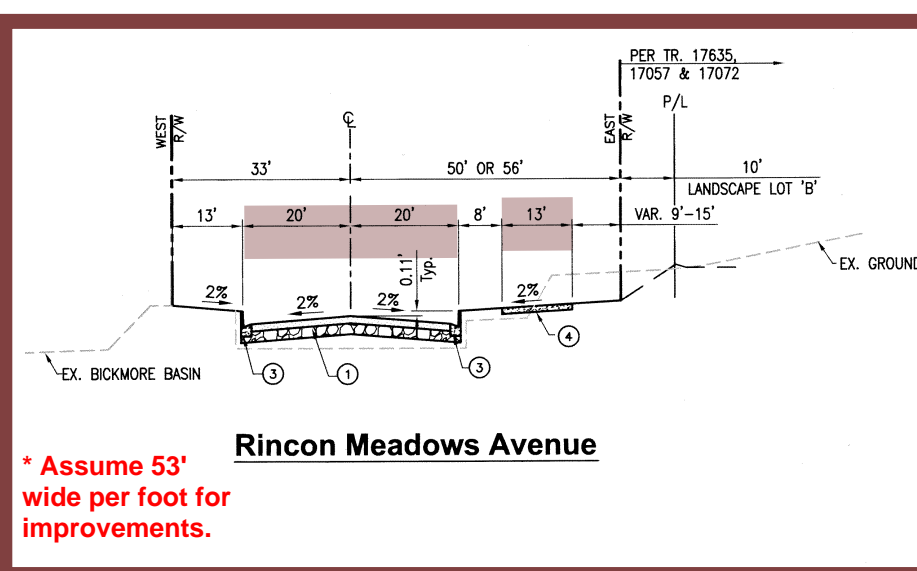

Assume 53' wide improvements:
53' x 1,456 LF = 77,168 SF

Street Name	Street SF	Total SF (All Streets)	% of Total	Total Cost (All Streets)	Total Street Cost
Street Cost				\$5,266,565.90	
AM/FP/MV Streetscape				\$ (649,812.34)	
Alpine Meadows Ave				\$ (203,546.20)	
Forest Park Street				\$ (136,064.50)	
Meadow Valley Ave				\$ (113,885.20)	
DIF Street Total				\$4,163,257.66	
Bickmore Ave	87,200	469,945	18.56%	\$4,163,257.66	\$772,507.57
Hellman Ave	29,055	469,945	6.18%	\$4,163,257.66	\$257,399.17
Kimball Ave	125,663	469,945	26.74%	\$4,163,257.66	\$1,113,252.50
Mill Creek Ave	6,780	469,945	1.44%	\$4,163,257.66	\$60,064.24
Rincon Meadows Ave	77,168	469,945	16.42%	\$4,163,257.66	\$683,633.76
Pine Ave #1	26,689	469,945	5.68%	\$4,163,257.66	\$236,438.70
Pine Ave #2	117,390	469,945	24.98%	\$4,163,257.66	\$1,039,961.73
	469,945		100.00%		\$4,163,257.66

